

20D 系列双卡套接头

1379 bar (20,000 psig)



接头
钢管
快速接头
过滤器
阀门
酸性介质产品
海底阀
型号互换表

目录

卡套螺母 - N



A-11

前卡套 - FF



A-11

后卡套 - RF



A-11

堵头 - DTP



A-11

管帽 - DTC

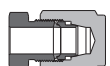

A-11

等径直通接头 - DU



A-12

变径直通接头 - DU



A-12

穿板固定接头 - DBU



A-12

卡套阳螺纹直通接头 - DCM

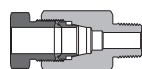

A-13

卡套阴螺纹直通接头 - DCF

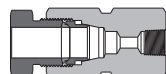

A-14

等径弯头 - DLU

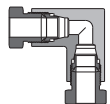

A-14

变径弯头 - DLU

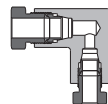

A-14

卡套阳螺纹弯头 - DLM

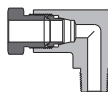

A-15

等径三通接头 - DT

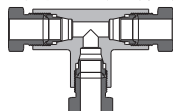

A-15

支管阳螺纹三通接头 - DT

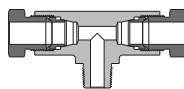

A-16

等径四通接头 - DX

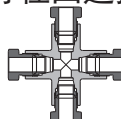

A-16

变径转换接头 - DR



A-17

端口接头 - DP



A-17

转换接头 - DAM

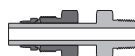

A-17

安装说明

A-106

接口信息

A-02

型号说明

A-18

特征

- ◎ 工作压力最大可达 1379 bar (20,000 psig)
- ◎ 方便、快速连接 T15A、T20D 和 T20M 系列无缝直管，适用于外径为 1/8"、1/4"、3/8"、1/2"、9/16"、3/4" 和 1" 的无缝直管
- ◎ 高强度 316 不锈钢材质
- ◎ 卡套螺母外螺纹上喷涂二硫化钼，减少摩擦
- ◎ 较长的管子支撑面提高了管路抗振性与负载能力
- ◎ 每个接头都刻有尺寸、材料和追溯码
- ◎ 通过了欧盟 EC-79 认证，可用于 70 MPa 的车载氢气系统

标准结构材料

元件	材料
本体、卡套	316 不锈钢
卡套螺母	316 不锈钢

与介质接触元件以斜体字列出。

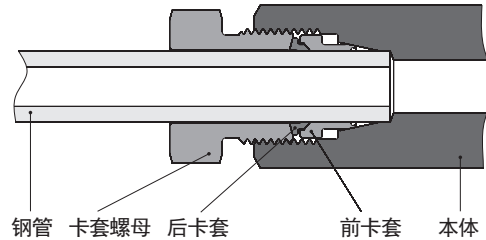

工作压力

- ◎ 工作压力取决于工作压力最低的连接端口。

Tube 管端

在环境温度下，Tube 管端的工作压力取决于使用的钢管工作压力，参考 B-06 和 B-08 环境温度下工作压力。

警告：20D 系列双卡套接头可以与 T20M 系列中高压管连接使用，但不是最佳搭配。推荐 20D 系列双卡套接头与 T20D 系列钢管连接使用，可达到最佳使用效果。

SAE O形圈密封阳螺纹端

SAE O形圈密封阳螺纹端接口工作压力为 690 bar (10,000 psig)。

NPT 螺纹端

NPT 尺寸 in.	工作压力 bar (psig)
1/8	1034 (15,000)
1/4	
3/8	
1/2	
3/4	690 (10,000)
1	

T20D 系列钢管

工作压力根据 ASME B31.3 第 IX 章“高压管道”计算。

外径 in.	壁厚 in.	工作压力 bar (psig)
1/4	0.065	1,379 (20,000)
3/8	0.083	
1/2	0.109	
3/4	0.165	
1	0.172	1,220 (17,800)

工作温度

接口类型	工作温度范围 °C (°F)
Tube 管端	-198 至 427 (-325 至 800)
SAE O形圈密封阳螺纹端	-17.8 至 204 (0 至 400) ^①
NPT 螺纹端	-198 至 204 (-325 至 400) ^{②③}

① 接头配有氟橡胶 O 形圈，其他材料 O 形圈也可提供。

② 在锥螺纹上始终使用适当的螺纹密封剂。

③ 数据基于螺纹密封剂的工作温度范围。工作温度高于 204°C (400°F) 时，请联系 FITOK 集团或其授权代理商。

接头

钢管

快速接头

过滤器

阀门

酸性介质产品

海底阀

型号互换表

订购信息和尺寸

尺寸仅为参考，可能会有改变。

卡套螺母

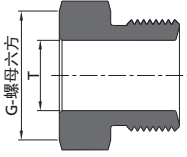

Tube 管		
T - Tube 管外径 in.	订购号	尺寸 in. (mm)
		G
1/8	SS-N-DFF2	0.37 (9.5)
1/4	SS-N-DFF4	0.63 (15.9)
3/8	SS-N-DFF6	0.75 (19.1)
1/2	SS-N-DFF8	0.94 (23.8)
9/16	SS-N-DFF9	1.06 (27.0)
3/4	SS-N-DFF12	1.38 (34.9)
1	SS-N-DFF16	1.88 (47.6)

前卡套

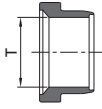

Tube 管	
T - Tube 管外径 in.	订购号
1/8	SS-FF-DFF2
1/4	SS-FF-DFF4
3/8	SS-FF-DFF6
1/2	SS-FF-DFF8
9/16	SS-FF-DFF9
3/4	SS-FF-DFF12
1	SS-FF-DFF16

后卡套



Tube 管	
T - Tube 管外径 in.	订购号
1/8	SS-RF-DFF2
1/4	SS-RF-DFF4
3/8	SS-RF-DFF6
1/2	SS-RF-DFF8
9/16	SS-RF-DFF9
3/4	SS-RF-DFF12
1	SS-RF-DFF16

堵头^①

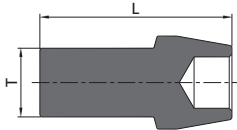

Tube 管		
T - Tube 管外径 in.	订购号	尺寸 in. (mm)
		L
1/8	SS-DTP-DFF2	0.95 (24.2)
1/4	SS-DTP-DFF4	1.20 (30.4)
3/8	SS-DTP-DFF6	1.19 (30.2)
1/2	SS-DTP-DFF8	1.36 (34.6)
9/16	SS-DTP-DFF9	1.73 (44.0)
3/4	SS-DTP-DFF12	2.30 (58.3)
1	SS-DTP-DFF16	2.64 (67.0)

① 使用堵头时，不需要卡套。

管帽

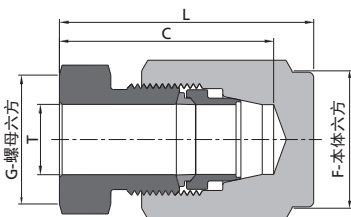

Tube 管					
T - Tube 管外径 in.	订购号	尺寸 in. (mm)			
		L	C	F	G
1/8	SS-DTC-DFF2	1.22 (31.1)	1.07 (27.2)	0.50 (12.7)	0.37 (9.5)
1/4	SS-DTC-DFF4	1.70 (43.1)	1.38 (35.2)	0.63 (15.9)	0.63 (15.9)
3/8	SS-DTC-DFF6	1.76 (44.8)	1.42 (36.1)	0.75 (19.1)	0.75 (19.1)
1/2	SS-DTC-DFF8	1.85 (47.0)	1.56 (39.6)	1.00 (25.4)	0.94 (23.8)
9/16	SS-DTC-DFF9	2.46 (62.6)	1.93 (49.0)	1.13 (28.6)	1.06 (27.0)
3/4	SS-DTC-DFF12	3.22 (81.9)	2.49 (63.3)	1.50 (38.1)	1.38 (34.9)
1	SS-DTC-DFF16	4.06 (103.2)	3.24 (82.3)	2.00 (50.8)	1.88 (47.6)

等径直通接头

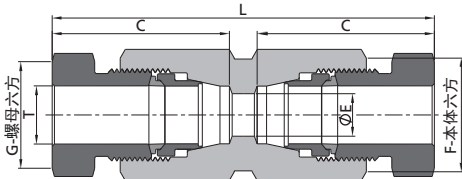

Tube 管		尺寸 in. (mm)				
T - Tube 管外径 in.	订购号	L	C	E	F	G
1/8	SS-DU-DFF2	2.45 (62.2)	1.07 (27.2)	0.09 (2.4)	0.50 (12.7)	0.37 (9.5)
1/4	SS-DU-DFF4	3.00 (76.2)	1.38 (35.2)	0.19 (4.8)	0.63 (15.9)	0.63 (15.9)
3/8	SS-DU-DFF6	3.07 (77.9)	1.42 (36.1)	0.25 (6.4)	0.75 (19.1)	0.75 (19.1)
1/2	SS-DU-DFF8	3.36 (85.4)	1.56 (39.6)	0.37 (9.5)	1.00 (25.4)	0.94 (23.8)
9/16	SS-DU-DFF9	4.11 (104.4)	1.93 (49.0)	0.41 (10.4)	1.13 (28.6)	1.06 (27.0)
3/4	SS-DU-DFF12	5.38 (136.7)	2.49 (63.3)	0.56 (14.2)	1.50 (38.1)	1.38 (34.9)
1	SS-DU-DFF16	7.06 (179.3)	3.24 (82.3)	0.69 (17.5)	1.20 (50.8)	1.88 (47.6)

变径直通接头

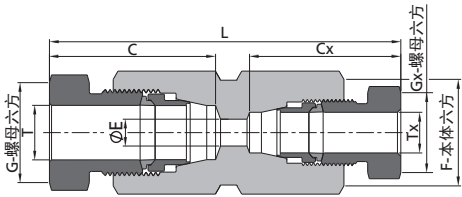

Tube 管			尺寸 in. (mm)						
T - Tube 管外径 in.	Tx - Tube 管外径 in.	订购号	L	C	Cx	E	F	G	Gx
1/4	1/8	SS-DU-DFF4-DFF2	2.73 (69.4)	1.39 (35.2)	1.07 (27.2)	0.09 (2.4)	0.63 (15.9)	0.63 (15.9)	0.37 (9.5)
3/8	1/8	SS-DU-DFF6-DFF2	2.77 (70.3)	1.42 (36.1)	1.07 (27.2)	0.09 (2.4)	0.75 (19.1)	0.75 (19.1)	0.37 (9.5)
3/8	1/4	SS-DU-DFF6-DFF4	3.06 (77.6)	1.42 (36.1)	1.39 (35.2)	0.19 (4.8)	0.75 (19.1)	0.75 (19.1)	0.63 (15.9)
1/2	1/4	SS-DU-DFF8-DFF4	3.35 (85.1)	1.56 (39.6)	1.39 (35.2)	0.19 (4.8)	1.00 (25.4)	0.94 (23.8)	0.63 (15.9)
1/2	3/8	SS-DU-DFF8-DFF6	3.32 (84.3)	1.56 (39.6)	1.42 (36.1)	0.25 (6.4)	1.00 (25.4)	0.94 (23.8)	0.75 (19.1)
9/16	1/2	SS-DU-DFF9-DFF8	4.04 (102.5)	1.93 (49.0)	1.56 (39.6)	0.37 (9.5)	1.13 (28.6)	1.06 (27.0)	0.94 (23.8)
3/4	1/2	SS-DU-DFF12-DFF8	4.73 (120.2)	2.49 (63.3)	1.56 (39.6)	0.37 (9.5)	1.50 (38.1)	1.38 (34.9)	0.94 (23.8)
1	1/2	SS-DU-DFF16-DFF8	5.35 (135.9)	3.24 (82.3)	1.56 (39.6)	0.37 (9.5)	2.00 (50.8)	1.88 (47.6)	0.94 (23.8)

穿板固定接头

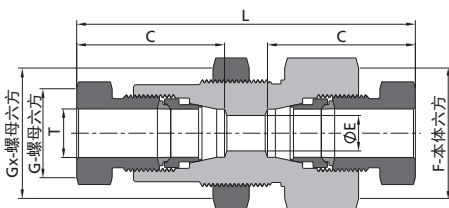

Tube 管		尺寸 in. (mm)							
T - Tube 管外径 in.	订购号	L	C	E	F	G	Gx	面板孔尺寸	最大面板厚度
1/8	SS-DBU-DFF2	2.95 (75.0)	1.07 (27.2)	0.09 (2.4)	0.75 (19.1)	0.37 (9.5)	0.81 (20.6)	0.69 (17.5)	0.38 (9.7)
1/4	SS-DBU-DFF4	3.27 (83.1)	1.38 (35.2)	0.19 (4.8)	1.00 (25.4)	0.63 (15.9)	1.06 (27.0)	0.94 (23.9)	0.38 (9.7)
3/8	SS-DBU-DFF6	3.21 (81.6)	1.42 (36.1)	0.25 (6.4)	1.00 (25.4)	0.75 (19.1)	1.06 (27.0)	0.94 (23.9)	0.38 (9.7)
1/2	SS-DBU-DFF8	3.93 (99.8)	1.56 (39.6)	0.37 (9.5)	1.38 (34.9)	0.94 (23.8)	1.38 (34.9)	1.13 (28.6)	0.38 (9.7)
9/16	SS-DBU-DFF9	4.64 (117.8)	1.93 (49.0)	0.41 (10.4)	1.63 (41.3)	1.06 (27.0)	1.63 (41.3)	1.33 (33.7)	0.38 (9.7)
3/4	SS-DBU-DFF12	5.82 (147.9)	2.49 (63.3)	0.56 (14.2)	1.87 (47.6)	1.38 (34.9)	1.87 (47.6)	1.64 (41.7)	0.38 (9.7)
1	SS-DBU-DFF16	7.45 (189.3)	3.24 (82.3)	0.69 (17.5)	2.50 (63.5)	1.88 (47.6)	2.50 (63.5)	2.27 (57.6)	0.38 (9.7)

A-13 20D 系列双卡套接头

卡套阳螺纹直通接头

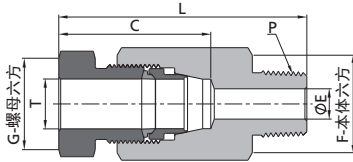

Tube 管			NPT 螺纹				
T - Tube 管外径 in.	P - NPT 尺寸 in.	订购号	尺寸 in. (mm)				
			L	C	E	F	G
1/8	1/8	SS-DCM-DFF2-NS2	1.60 (40.6)	1.07 (27.2)	0.09 (2.4)	0.50 (12.7)	0.37 (9.5)
1/8	1/4	SS-DCM-DFF2-NS4	1.72 (43.8)	1.07 (27.2)	0.09 (2.4)	0.56 (14.3)	0.37 (9.5)
1/8	3/8	SS-DCM-DFF2-NS6	1.72 (43.8)	1.07 (27.2)	0.09 (2.4)	0.69 (17.5)	0.37 (9.5)
1/4	1/8	SS-DCM-DFF4-NS2	1.95 (49.5)	1.39 (35.2)	0.19 (4.8)	0.63 (15.9)	0.63 (15.9)
1/4	1/4	SS-DCM-DFF4-NS4	2.08 (52.8)	1.39 (35.2)	0.19 (4.8)	0.63 (15.9)	0.63 (15.9)
1/4	3/8	SS-DCM-DFF4-NS6	2.08 (52.8)	1.39 (35.2)	0.19 (4.8)	0.69 (17.5)	0.63 (15.9)
1/4	1/2	SS-DCM-DFF4-NS8	2.32 (59.0)	1.39 (35.2)	0.19 (4.8)	0.87 (22.2)	0.63 (15.9)
3/8	1/4	SS-DCM-DFF6-NS4	2.17 (55.1)	1.42 (36.1)	0.25 (6.4)	0.75 (19.1)	0.75 (19.1)
3/8	3/8	SS-DCM-DFF6-NS6	2.17 (55.1)	1.42 (36.1)	0.25 (6.4)	0.75 (19.1)	0.75 (19.1)
3/8	1/2	SS-DCM-DFF6-NS8	2.30 (58.3)	1.42 (36.1)	0.25 (6.4)	0.87 (22.2)	0.75 (19.1)
1/2	1/4	SS-DCM-DFF8-NS4	2.53 (64.3)	1.56 (39.6)	0.25 (6.4)	1.00 (25.4)	0.94 (23.8)
1/2	3/8	SS-DCM-DFF8-NS6	2.53 (64.3)	1.56 (39.6)	0.31 (7.9)	1.00 (25.4)	0.94 (23.8)
1/2	1/2	SS-DCM-DFF8-NS8	2.65 (67.4)	1.56 (39.6)	0.37 (9.5)	1.00 (25.4)	0.94 (23.8)
1/2	3/4	SS-DCM-DFF8-NS12	2.53 (64.3)	1.56 (39.6)	0.37 (9.5)	1.06 (27.0)	0.94 (23.8)
9/16	1/4	SS-DCM-DFF9-NS4	3.03 (77.0)	1.93 (49.0)	0.25 (6.4)	1.13 (28.6)	1.06 (27.0)
9/16	1/2	SS-DCM-DFF9-NS8	3.11 (79.1)	1.93 (49.0)	0.38 (9.6)	1.13 (28.6)	1.06 (27.0)
3/4	1/2	SS-DCM-DFF12-NS8	3.74 (95.1)	2.49 (63.3)	0.38 (9.6)	1.50 (38.1)	1.38 (34.9)
3/4	3/4	SS-DCM-DFF12-NS12	3.74 (95.1)	2.49 (63.3)	0.56 (14.2)	1.50 (38.1)	1.38 (34.9)
3/4	1	SS-DCM-DFF12-NS16	3.83 (97.4)	2.49 (63.3)	0.56 (14.2)	1.50 (38.1)	1.38 (34.9)
1	1/2	SS-DCM-DFF16-NS8	4.46 (113.2)	3.24 (82.3)	0.38 (9.6)	2.00 (50.8)	1.88 (47.6)
1	3/4	SS-DCM-DFF16-NS12	4.46 (113.2)	3.24 (82.3)	0.58 (14.8)	2.00 (50.8)	1.88 (47.6)
1	1	SS-DCM-DFF16-NS16	4.65 (118.1)	3.24 (82.3)	0.69 (17.5)	2.00 (50.8)	1.88 (47.6)

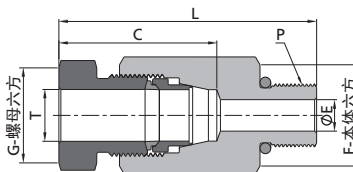

Tube 管			SAE O形圈密封阳螺纹				
T - Tube 管外径 in.	P - SAE/MS 螺纹 尺寸	订购号	尺寸 in. (mm)				
			L	C	E	F	G
1/8	7/16-20	SS-DCM-DFF2-SH7	1.60 (40.6)	1.07 (27.2)	0.09 (2.4)	0.56 (14.3)	0.37 (9.5)
1/8	9/16-18	SS-DCM-DFF2-SH9	1.66 (42.2)	1.07 (27.2)	0.09 (2.4)	0.69 (17.5)	0.37 (9.5)
1/4	7/16-20	SS-DCM-DFF4-SH7	2.04 (51.7)	1.39 (35.2)	0.18 (4.5)	0.63 (15.9)	0.63 (15.9)
1/4	9/16-18	SS-DCM-DFF4-SH9	2.07 (52.7)	1.39 (35.2)	0.19 (4.8)	0.69 (17.5)	0.63 (15.9)
3/8	7/16-20	SS-DCM-DFF6-SH7	2.09 (53.0)	1.42 (36.1)	0.18 (4.5)	0.75 (19.1)	0.75 (19.1)
3/8	9/16-18	SS-DCM-DFF6-SH9	2.13 (54.0)	1.42 (36.1)	0.25 (6.4)	0.75 (19.1)	0.75 (19.1)
1/2	7/16-20	SS-DCM-DFF8-SH7	2.49 (63.3)	1.56 (39.6)	0.18 (4.5)	1.00 (25.4)	0.94 (23.8)
1/2	9/16-18	SS-DCM-DFF8-SH9	2.49 (63.3)	1.56 (39.6)	0.30 (7.5)	1.00 (25.4)	0.94 (23.8)

卡套阴螺纹直通接头

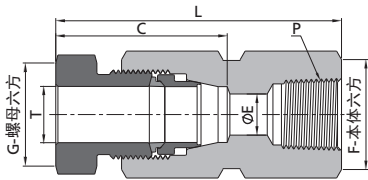

Tube 管				NPT 螺纹				
T - Tube 管外径 in.	P - NPT 尺寸 in.	订购号	尺寸 in. (mm)					
			L	C	E	F	G	
1/8	1/8	SS-DCF-DFF2-FNS2	1.97 (50.1)	1.07 (27.2)	0.09 (2.4)	0.63 (15.9)	0.37 (9.5)	
1/8	1/4	SS-DCF-DFF2-FNS4	2.01 (53.3)	1.07 (27.2)	0.09 (2.4)	0.94 (23.8)	0.37 (9.5)	
1/4	1/4	SS-DCF-DFF4-FNS4	2.33 (59.1)	1.38 (35.2)	0.19 (4.8)	0.94 (23.8)	0.63 (15.9)	
3/8	1/4	SS-DCF-DFF6-FNS4	2.29 (58.1)	1.42 (36.1)	0.25 (6.4)	0.94 (23.8)	0.75 (19.1)	
1/2	1/4	SS-DCF-DFF8-FNS4	2.78 (70.6)	1.56 (39.6)	0.37 (9.5)	1.00 (25.4)	0.94 (23.8)	
1/2	1/2	SS-DCF-DFF8-FNS8	3.03 (77.0)	1.56 (39.6)	0.37 (9.5)	1.38 (34.9)	0.94 (23.8)	
3/4	1/2	SS-DCF-DFF12-FNS8	3.85 (97.8)	2.49 (63.3)	0.56 (14.2)	1.50 (38.1)	1.38 (34.9)	
1	1	SS-DCF-DFF16-FNS16	4.75 (120.7)	3.24 (82.3)	0.69 (17.5)	2.00 (50.8)	1.88 (47.6)	

等径弯头

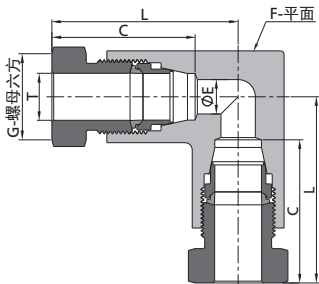

Tube 管		尺寸 in. (mm)				
T - Tube 管外径 in.	订购号	L	C	E	F	G
1/8	SS-DLU-DFF2	1.29 (32.7)	1.07 (27.2)	0.09 (2.4)	0.63 (15.9)	0.37 (9.5)
1/4	SS-DLU-DFF4	1.70 (43.1)	1.38 (35.2)	0.19 (4.8)	0.63 (15.9)	0.63 (15.9)
3/8	SS-DLU-DFF6	1.67 (42.4)	1.42 (36.1)	0.25 (6.4)	0.75 (19.1)	0.75 (19.1)
1/2	SS-DLU-DFF8	2.03 (51.6)	1.56 (39.6)	0.37 (9.5)	1.00 (25.4)	0.94 (23.8)
9/16	SS-DLU-DFF9	2.43 (61.8)	1.93 (49.0)	0.41 (10.4)	1.38 (34.9)	1.06 (27.0)
3/4	SS-DLU-DFF12	3.11 (79.1)	2.49 (63.3)	0.56 (14.2)	1.50 (38.1)	1.38 (34.9)
1	SS-DLU-DFF16	4.14 (105.2)	3.24 (82.3)	0.69 (17.5)	2.25 (57.2)	1.88 (47.6)

变径弯头

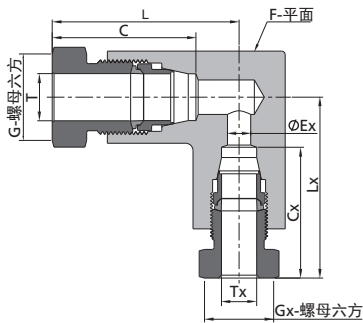

Tube 管			尺寸 in. (mm)							
T - Tube 管外径 in.	Tx - Tube 管外径 in.	订购号	L	Lx	C	Cx	Ex	F	G	Gx
1/4	1/8	SS-DLU-DFF4-DFF2	1.70 (43.1)	1.37 (34.7)	1.38 (35.2)	1.07 (27.2)	0.09 (2.4)	0.63 (15.9)	0.63 (15.9)	0.37 (9.5)
3/8	1/8	SS-DLU-DFF6-DFF2	1.67 (42.4)	1.33 (33.7)	1.42 (36.1)	1.07 (27.2)	0.09 (2.4)	0.75 (19.1)	0.75 (19.1)	0.37 (9.5)
3/8	1/4	SS-DLU-DFF6-DFF4	1.67 (42.4)	1.70 (43.1)	1.42 (36.1)	1.38 (35.2)	0.19 (4.8)	0.75 (19.1)	0.75 (19.1)	0.63 (15.9)
1/2	1/4	SS-DLU-DFF8-DFF4	2.03 (51.6)	1.95 (49.5)	1.56 (39.6)	1.38 (35.2)	0.19 (4.8)	0.94 (23.8)	1.00 (25.4)	0.63 (15.9)
1/2	3/8	SS-DLU-DFF8-DFF6	2.03 (51.6)	1.96 (49.8)	1.56 (39.6)	1.42 (36.1)	0.25 (6.4)	0.94 (23.8)	1.00 (25.4)	0.75 (19.1)
9/16	1/2	SS-DLU-DFF9-DFF8	2.43 (61.8)	2.37 (60.2)	1.93 (49.0)	1.56 (39.6)	0.37 (9.5)	1.38 (34.9)	1.06 (27.0)	0.94 (23.8)
3/4	1/2	SS-DLU-DFF12-DFF8	3.11 (79.1)	2.49 (63.3)	2.49 (63.3)	1.56 (39.6)	0.37 (9.5)	1.50 (38.1)	1.38 (34.9)	0.94 (23.8)
1	1/2	SS-DLU-DFF16-DFF8	4.14 (105.2)	2.47 (62.8)	3.24 (82.3)	1.56 (39.6)	0.37 (9.5)	2.25 (57.2)	1.88 (47.6)	0.94 (23.8)
1	9/16	SS-DLU-DFF16-DFF9	4.14 (105.2)	2.82 (71.6)	3.24 (82.3)	1.93 (49.0)	0.41 (10.4)	2.25 (57.2)	1.88 (47.6)	1.06 (27.0)
1	3/4	SS-DLU-DFF16-DFF12	4.14 (105.2)	3.45 (87.6)	3.24 (82.3)	2.49 (63.3)	0.56 (14.2)	2.25 (57.2)	1.88 (47.6)	1.38 (34.9)

接头

钢管

快速接头

过滤器

阀门

酸性介质产品

海底阀

型号互换表

A-15 20D 系列双卡套接头

卡套阳螺纹弯头

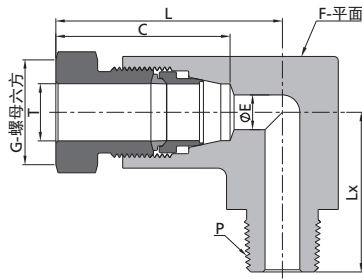

Tube 管			NPT 螺纹					
T - Tube 管外径 in.	P - NPT 尺寸 in.	订购号	尺寸 in. (mm)					
			L	Lx	C	E	F	G
1/8	1/8	SS-DLM-DFF2-NS2	1.29 (32.7)	0.79 (20.0)	1.07 (27.2)	0.09 (2.4)	0.63 (15.9)	0.37 (9.5)
1/8	1/4	SS-DLM-DFF2-NS4	1.39 (35.3)	1.00 (25.4)	1.07 (27.2)	0.09 (2.4)	0.63 (15.9)	0.37 (9.5)
1/8	3/8	SS-DLM-DFF2-NS6	1.47 (37.4)	1.00 (25.4)	1.07 (27.2)	0.09 (2.4)	0.75 (19.1)	0.37 (9.5)
1/4	1/4	SS-DLM-DFF4-NS4	1.70 (43.1)	0.94 (23.8)	1.38 (35.2)	0.19 (4.8)	0.63 (15.9)	0.63 (15.9)
1/4	3/8	SS-DLM-DFF4-NS6	1.70 (43.1)	1.00 (25.4)	1.38 (35.2)	0.19 (4.8)	0.75 (19.1)	0.63 (15.9)
1/4	1/2	SS-DLM-DFF4-NS8	1.70 (43.1)	1.38 (34.9)	1.38 (35.2)	0.19 (4.8)	1.00 (25.4)	0.63 (15.9)
3/8	1/4	SS-DLM-DFF6-NS4	1.67 (42.4)	1.00 (25.4)	1.42 (36.1)	0.25 (6.4)	0.75 (19.1)	0.75 (19.1)
3/8	3/8	SS-DLM-DFF6-NS6	1.67 (42.4)	1.06 (27.0)	1.42 (36.1)	0.25 (6.4)	0.75 (19.1)	0.75 (19.1)
3/8	1/2	SS-DLM-DFF6-NS8	1.67 (42.4)	1.38 (34.9)	1.42 (36.1)	0.25 (6.4)	1.00 (25.4)	0.75 (19.1)
1/2	1/4	SS-DLM-DFF8-NS4	2.03 (51.6)	1.19 (30.2)	1.56 (39.6)	0.25 (6.4)	1.00 (25.4)	0.94 (23.8)
1/2	3/8	SS-DLM-DFF8-NS6	2.03 (51.6)	1.19 (30.2)	1.56 (39.6)	0.31 (7.9)	1.00 (25.4)	0.94 (23.8)
1/2	1/2	SS-DLM-DFF8-NS8	2.03 (51.6)	1.38 (34.9)	1.56 (39.6)	0.37 (9.5)	1.00 (25.4)	0.94 (23.8)
9/16	1/2	SS-DLM-DFF9-NS8	2.43 (61.8)	1.56 (39.5)	1.93 (49.0)	0.38 (9.6)	1.38 (34.9)	1.06 (27.0)
3/4	1/2	SS-DLM-DFF12-NS8	3.11 (79.1)	1.73 (44.0)	2.49 (63.3)	0.38 (9.6)	1.50 (38.1)	1.38 (34.9)
3/4	3/4	SS-DLM-DFF12-NS12	3.11 (79.1)	1.73 (44.0)	2.49 (63.3)	0.56 (14.2)	1.50 (38.1)	1.38 (34.9)
1	1/2	SS-DLM-DFF16-NS8	4.14 (105.2)	2.06 (52.4)	3.24 (82.3)	0.38 (9.6)	2.25 (57.2)	1.88 (47.6)
1	3/4	SS-DLM-DFF16-NS12	4.14 (105.2)	2.06 (52.4)	3.24 (82.3)	0.58 (14.8)	2.25 (57.2)	1.88 (47.6)
1	1 1/2	SS-DLM-DFF16-NS16	4.14 (105.2)	2.25 (57.2)	3.24 (82.3)	0.69 (17.5)	2.25 (57.2)	1.88 (47.6)

等径三通接头

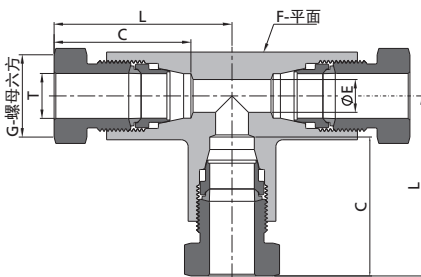

Tube 管		尺寸 in. (mm)				
T - Tube 管外径 in.	订购号	L	C	E	F	G
1/8	SS-DT-DFF2	1.37 (34.7)	1.07 (27.2)	0.09 (2.4)	0.63 (15.9)	0.37 (9.5)
1/4	SS-DT-DFF4	1.70 (43.1)	1.38 (35.2)	0.19 (4.8)	0.63 (15.9)	0.63 (15.9)
3/8	SS-DT-DFF6	1.67 (42.4)	1.42 (36.1)	0.25 (6.4)	0.75 (19.1)	0.75 (19.1)
1/2	SS-DT-DFF8	2.03 (51.6)	1.56 (39.6)	0.37 (9.5)	1.00 (25.4)	0.94 (23.8)
9/16	SS-DT-DFF9	2.43 (61.8)	1.93 (49.0)	0.41 (10.4)	1.38 (34.9)	1.06 (27.0)
3/4	SS-DT-DFF12	3.11 (79.1)	2.49 (63.3)	0.56 (14.2)	1.50 (38.1)	1.38 (34.9)
1	SS-DT-DFF16	4.14 (105.2)	3.24 (82.3)	0.69 (17.5)	2.25 (57.2)	1.88 (47.6)

支管阳螺纹三通接头

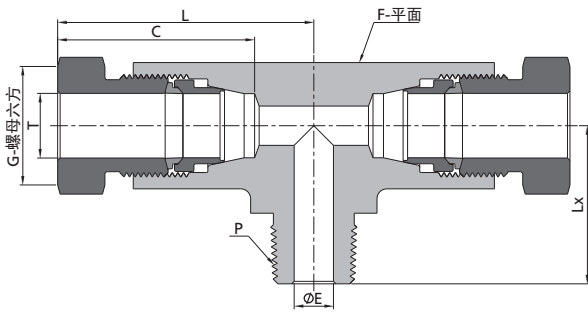

Tube 管			NPT 螺纹					
T - Tube 管外径 in.	P - NPT 尺寸 in.	订购号	尺寸 in. (mm)					
			L	Lx	C	E	F	G
1/8	1/8	SS-DT-DFF2-DFF2-NS2	1.37 (34.7)	0.79 (20.0)	1.07 (27.2)	0.09 (2.4)	0.63 (15.9)	0.37 (9.5)
1/8	1/4	SS-DT-DFF2-DFF2-NS4	1.37 (34.7)	1.00 (25.4)	1.07 (27.2)	0.09 (2.4)	0.63 (15.9)	0.37 (9.5)
1/4	1/8	SS-DT-DFF4-DFF4-NS2	1.70 (43.1)	0.81 (20.6)	1.38 (35.2)	0.19 (4.8)	0.63 (15.9)	0.63 (15.9)
1/4	1/4	SS-DT-DFF4-DFF4-NS4	1.70 (43.1)	1.00 (25.4)	1.38 (35.2)	0.19 (4.8)	0.63 (15.9)	0.63 (15.9)
3/8	1/4	SS-DT-DFF6-DFF6-NS4	1.67 (42.4)	1.06 (27.0)	1.42 (36.1)	0.25 (6.4)	0.75 (19.1)	0.75 (19.1)
1/2	1/4	SS-DT-DFF8-DFF8-NS4	2.03 (51.6)	1.19 (30.2)	1.56 (39.6)	0.25 (6.4)	1.00 (25.4)	0.94 (23.8)
1/2	3/8	SS-DT-DFF8-DFF8-NS6	2.03 (51.6)	1.19 (30.2)	1.56 (39.6)	0.31 (7.9)	1.00 (25.4)	0.94 (23.8)
3/4	3/4	SS-DT-DFF12-DFF12-NS12	3.11 (79.1)	1.73 (44.0)	2.49 (63.3)	0.56 (14.2)	1.50 (38.1)	1.38 (34.9)
1	1/2	SS-DT-DFF16-DFF16-NS8	4.14 (105.2)	2.06 (52.4)	3.24 (82.3)	0.38 (9.6)	2.25 (57.2)	1.88 (47.6)
1	3/4	SS-DT-DFF16-DFF16-NS12	4.14 (105.2)	2.06 (52.4)	3.24 (82.3)	0.58 (14.8)	2.25 (57.2)	1.88 (47.6)
1	1	SS-DT-DFF16-DFF16-NS16	4.14 (105.2)	2.25 (57.2)	3.24 (82.3)	0.69 (17.5)	2.25 (57.2)	1.88 (47.6)

等径四通接头

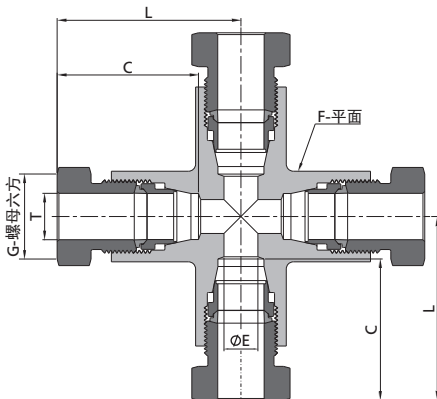

Tube 管		尺寸 in. (mm)				
T - Tube 管外径 in.	订购号	L	C	E	F	G
1/8	SS-DX-DFF2	1.37 (34.7)	1.07 (27.2)	0.09 (2.4)	0.63 (15.9)	0.37 (9.5)
1/4	SS-DX-DFF4	1.70 (43.1)	1.38 (35.2)	0.19 (4.8)	0.63 (15.9)	0.63 (15.9)
3/8	SS-DX-DFF6	1.67 (42.4)	1.42 (36.1)	0.25 (6.4)	0.75 (19.1)	0.75 (19.1)
1/2	SS-DX-DFF8	2.03 (51.6)	1.56 (39.6)	0.37 (9.5)	1.00 (25.4)	0.94 (23.8)
9/16	SS-DX-DFF9	2.43 (61.8)	1.93 (49.0)	0.41 (10.4)	1.38 (34.9)	1.06 (27.0)
3/4	SS-DX-DFF12	3.01 (76.4)	2.49 (63.3)	0.56 (14.2)	1.50 (38.1)	1.38 (34.9)
1	SS-DX-DFF16	4.14 (105.2)	3.24 (82.3)	0.69 (17.5)	2.25 (57.2)	1.88 (47.6)

接头

钢管

快速接头

过滤器

阀门

酸性介质产品

海底阀

型号互换表

A-17 20D 系列双卡套接头

变径转换接头^①

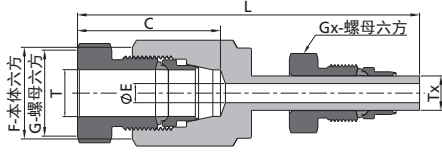

Tube			尺寸 in. (mm)						
T - Tube 管外径 in.	Tx - Tube 管外径 in.	订购号	L	C	E	F	G	Gx	
1/4	3/8	SS-DR-DFF4-DFT6	3.20 (82.1)	1.38 (35.2)	0.19 (4.8)	0.63 (15.9)	0.63 (15.9)	0.75 (19.1)	
1/4	1/2	SS-DR-DFF4-DFT8	3.37 (85.5)	1.38 (35.2)	0.19 (4.8)	0.63 (15.9)	0.63 (15.9)	0.94 (23.8)	
3/8	1/2	SS-DR-DFF6-DFT8	3.43 (87.1)	1.42 (36.1)	0.25 (6.4)	0.75 (19.1)	0.75 (19.1)	0.94 (23.8)	
1/2	3/8	SS-DR-DFF8-DFT6	3.53 (89.7)	1.56 (39.6)	0.21 (5.3)	1.00 (25.4)	0.94 (23.8)	0.75 (19.1)	
1/2	3/4	SS-DR-DFF8-DFT12	5.13 (130.4)	1.56 (39.6)	0.37 (9.5)	1.00 (25.4)	0.94 (23.8)	1.38 (34.9)	
9/16	3/4	SS-DR-DFF9-DFT12	5.32 (135.1)	1.93 (49.0)	0.41 (10.4)	1.13 (28.6)	1.06 (27.0)	1.38 (34.9)	
3/4	9/16	SS-DR-DFF12-DFT9	5.46 (138.6)	2.49 (63.3)	0.31 (7.9)	1.50 (38.1)	1.38 (34.9)	1.06 (27.0)	
1	1	SS-DR-DFF16-DFT12	6.92 (175.7)	3.24 (82.3)	0.42 (10.7)	2.00 (50.8)	1.88 (47.6)	1.38 (34.9)	

① 变径转换接头右端的卡套在出货前已预装，安装时，请按照 A-107 中的复装说明进行操作。

端口接头^①

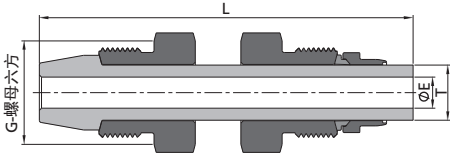

Tube 管		尺寸 in. (mm)		
T - Tube 管外径 in.	订购号	L	E	G
1/8	SS-DP-DFF2	2.06 (52.2)	0.06 (1.6)	0.37 (9.5)
1/4	SS-DP-DFF4	2.66 (67.5)	0.12 (3.0)	0.63 (15.9)
3/8	SS-DP-DFF6	2.72 (69.0)	0.21 (5.3)	0.75 (19.1)
1/2	SS-DP-DFF8	3.04 (77.3)	0.28 (7.1)	0.94 (23.8)
9/16	SS-DP-DFF9	3.80 (96.5)	0.31 (7.9)	1.06 (27.0)
3/4	SS-DP-DFF12	4.83 (122.8)	0.42 (10.7)	1.38 (34.9)
1	SS-DP-DFF16	5.98 (152.0)	0.66 (16.7)	1.88 (47.6)

① 端口接头的卡套在出货前已预装，安装时，请按照 A-107 中的复装说明进行操作。

转换接头^①

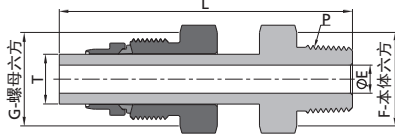

Tube 管			NPT 螺纹			
T - Tube 管外径 in.	P - NPT 尺寸	订购号	尺寸 in. (mm)			
			L	E	F	G
1/4	1/4	SS-DAM-DFT4-NS4	2.30 (58.5)	0.12 (3.0)	0.56 (14.3)	0.63 (15.9)
3/8	1/4	SS-DAM-DFT6-NS4	2.38 (60.4)	0.21 (5.3)	0.56 (14.3)	0.75 (19.1)
3/8	1/2	SS-DAM-DFT6-NS8	2.67 (67.9)	0.21 (5.3)	0.87 (22.2)	0.75 (19.1)
1/2	1/4	SS-DAM-DFT8-NS4	2.55 (64.8)	0.25 (6.4)	0.56 (14.3)	0.94 (23.8)
1/2	1/2	SS-DAM-DFT8-NS8	2.84 (72.2)	0.28 (7.1)	0.87 (22.2)	0.94 (23.8)
9/16	1/2	SS-DAM-DFT9-NS8	3.64 (92.4)	0.31 (7.9)	0.87 (22.2)	1.06 (27.0)
3/4	3/4	SS-DAM-DFT12-NS12	4.39 (111.6)	0.42 (10.7)	1.06 (27.0)	1.38 (34.9)
1	1	SS-DAM-DFT16-NS16	5.43 (137.9)	0.66 (16.7)	1.38 (34.9)	1.88 (47.6)

① 转换接头的卡套在出货前已预装，安装时，请按照 A-107 中的复装说明进行操作。

安装说明

见 A-106。

接口信息

见 A-02。

FITOK

接头

钢管

快速接头

过滤器

阀门

酸性介质产品

海底阀

型号互换表

型号说明

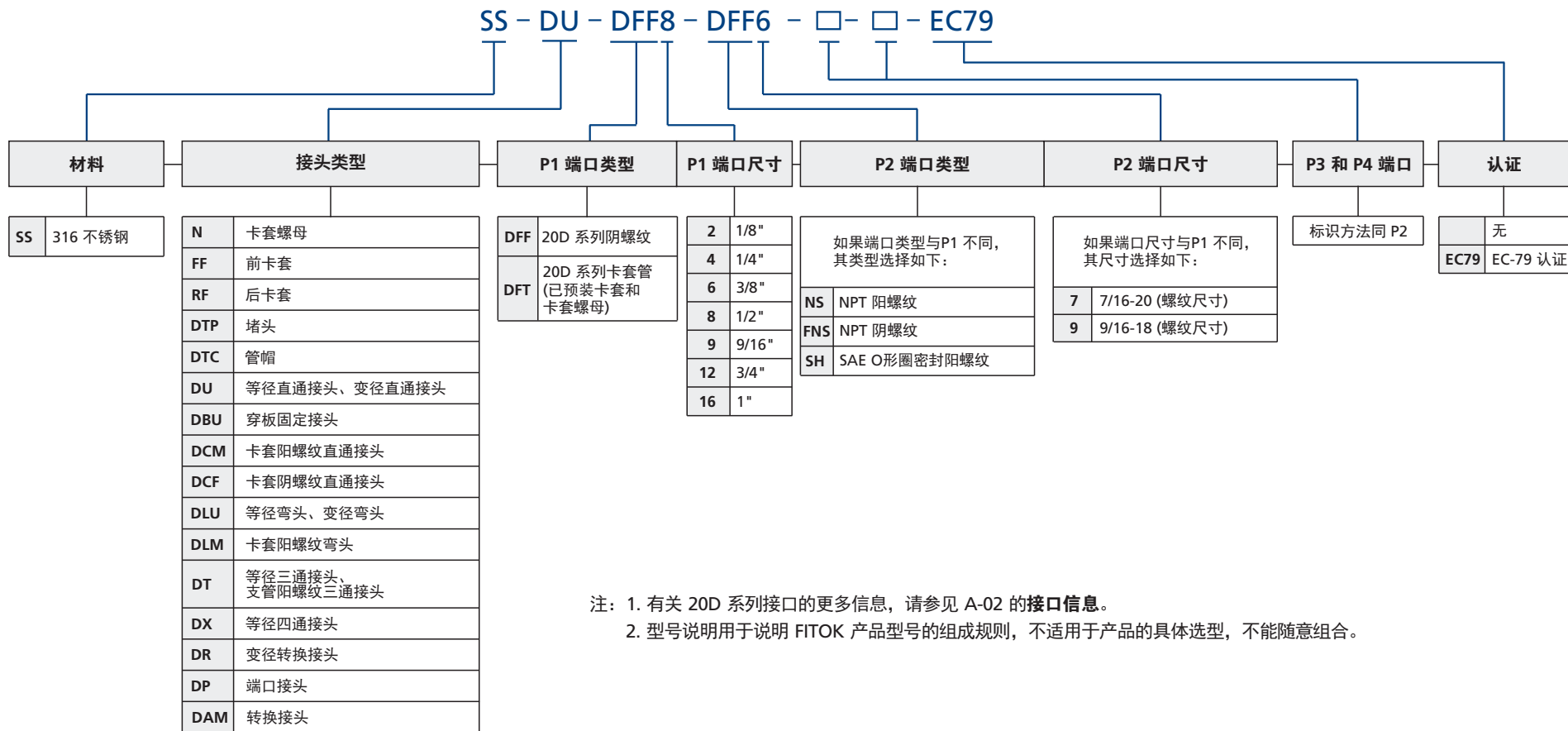

注: 1. 有关 20D 系列接口的更多信息, 请参见 A-02 的接口信息。
 2. 型号说明用于说明 FITOK 产品型号的组成规则, 不适用于产品的具体选型, 不能随意组合。

型号互换表	海底阀	酸性介质产品	阀门	过滤器	快速接头	钢管	接头
-------	-----	--------	----	-----	------	----	----