

Gauge Valves and Instrumentation Manifolds

GV, GVH, GR Series

2D, 2R, 2DH, 2RH Series 2-valve Manifolds

3D, 3R, 3DH, 3RH Series 3-valve Manifolds

5D, 5R, 5DH, 5RH Series 5-valve Manifolds

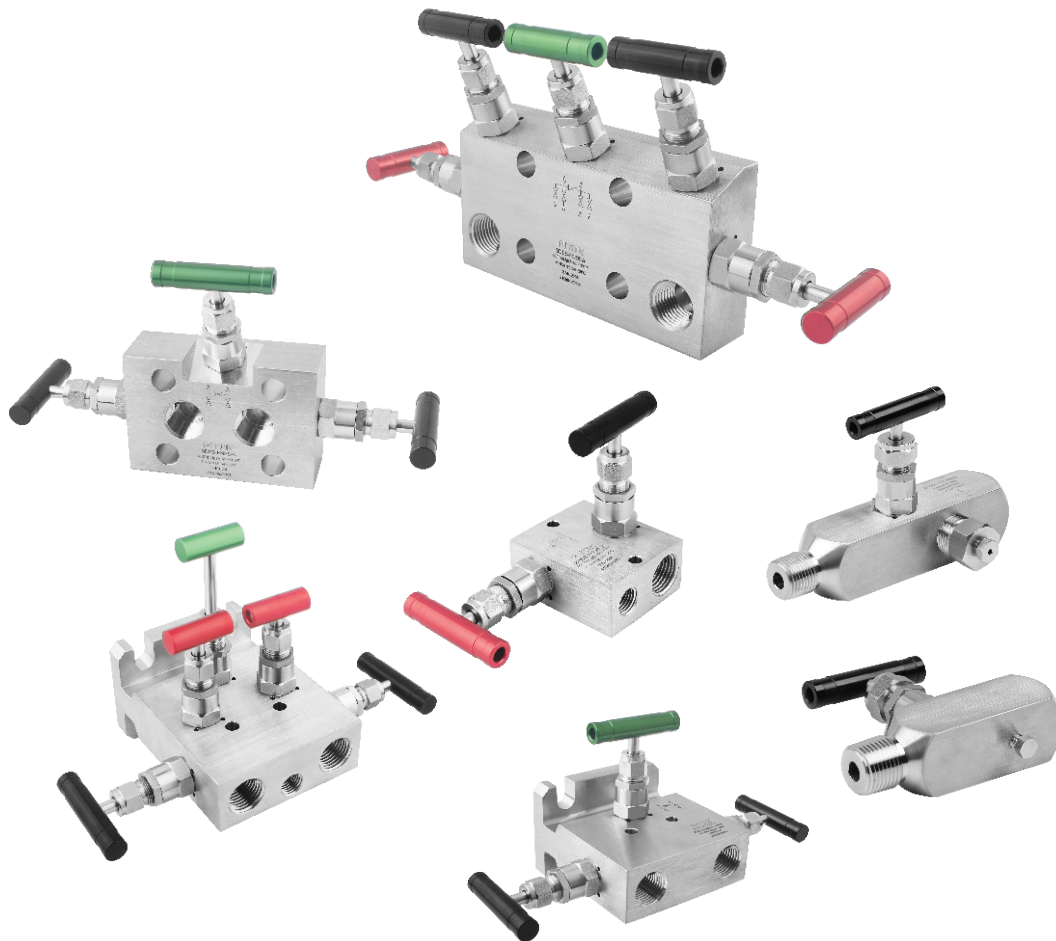

Contents

Gauge Valves

| | |
|------------------------------------|------|
| Features | C-04 |
| Standard Materials of Construction | C-04 |
| Pressure vs. Temperature | C-05 |
| Types and Dimensions | C-06 |
| Standard Type | C-06 |
| Lagging Extension Body Type | C-06 |
| Miniature Type | C-06 |

Instrumentation Manifolds

| | |
|--|------|
| Features | C-08 |
| Standard Materials of Construction | C-08 |
| Pressure vs. Temperature | C-09 |
| Design Standards | C-09 |
| Manifolds Mounting Application | C-10 |
| Types and Dimensions | C-12 |
| Remote Mount Manifolds | C-12 |
| Direct Mount Manifolds (transmitter with coplanar mounting flange) | C-17 |
| Direct Mount Manifolds (transmitter with traditional flange) | C-18 |
| Direct Mount Manifolds (transmitter without flange) | C-23 |

Accessories

| | |
|--------------------------------------|------|
| Manifold Mounting Bracket Kit | C-24 |
| Kidney Flanges and Eccentric Flanges | C-25 |

Notes:

- ⦿ Packing may need to be adjusted during valve use.
- ⦿ For better maintenance, FITOK gauge valves and instrumentation manifolds should be stored in the half-open position.

Gauge Valves

GV Series, GVH Series and GR Series

Features

- ⦿ Working pressure (stainless steel):
 GV, GR series up to 6000 psig (414 bar)
 GVH series up to 10000 psig (690 bar)
- ⦿ Working temperature:
 PTFE packing: -65°F to 450°F (-54°C to 232°C)
 Graphite packing: -65°F to 1200°F (-54°C to 649°C)
 Acetal seat: -20°F to 250°F (-28°C to 121°C)
 PEEK seat: -20°F to 400°F (-28°C to 204°C)
- ⦿ Orifice: GV and GVH Series: 0.157" (4.0 mm)
 GR Series: 0.25" (6.4 mm)
- ⦿ Non-rotating lower stem, GV/GVH series lower stem ball tip design, GR series lower stem plug stem design
- ⦿ Safety back seating seals in fully open position
- ⦿ Rolled spindle operating threads
- ⦿ Lubricant for stem thread isolated from the media
- ⦿ Externally adjustable gland
- ⦿ Bonnet locking pin fitted as standard
- ⦿ Option for different colored handles
- ⦿ Every gauge valve leak tested at factory at rated working pressure

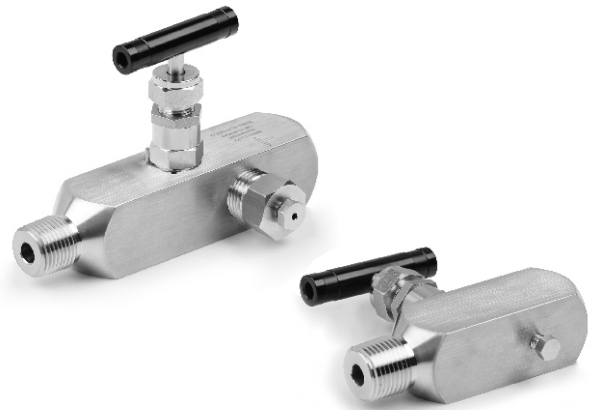

Standard Materials of Construction

| Item | Component | Material Grade/ASTM Specification |
|------|-------------------|--|
| 1 | Handle | Aluminum alloy |
| 2 | Set Screw | Zinc-plated carbon steel |
| 3 | Packing Bolt | 304 SS/A479 |
| 4 | Upper Stem | 316 SS/A479 |
| 5 | Lock Nut | Stainless steel |
| 6 | <i>Bonnet</i> | <i>316 SS/A479</i> |
| 7 | Gland | 316 SS/A479 |
| 8 | <i>Packing</i> | <i>PTFE or graphite</i> |
| 9 | Lock Pin | Stainless steel |
| 10 | <i>Lower Stem</i> | <i>Hardened 316 SS/A479</i> |
| 11 | <i>Body</i> | <i>316 SS/A479 316 SS/A182</i> |
| 12 | <i>Seat</i> | <i>Acetal or PEEK (GR series only)</i> |
| | <i>Lubricant</i> | <i>Molybdenum disulfide-based</i> |

Note: Wetted components are listed in italics.

Ball Tip Design Valves (GV, GVH)

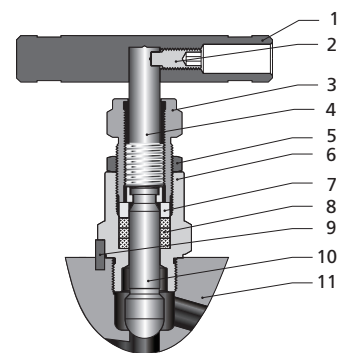

Plug Tip Design Valves (GR)

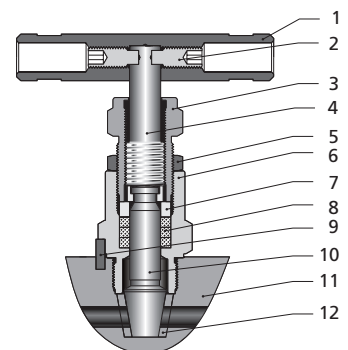

Pressure vs. Temperature

GV Series

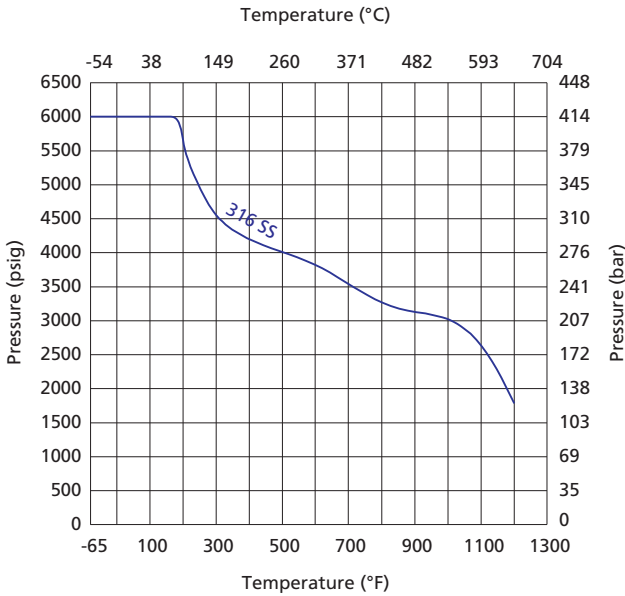

GVH Series

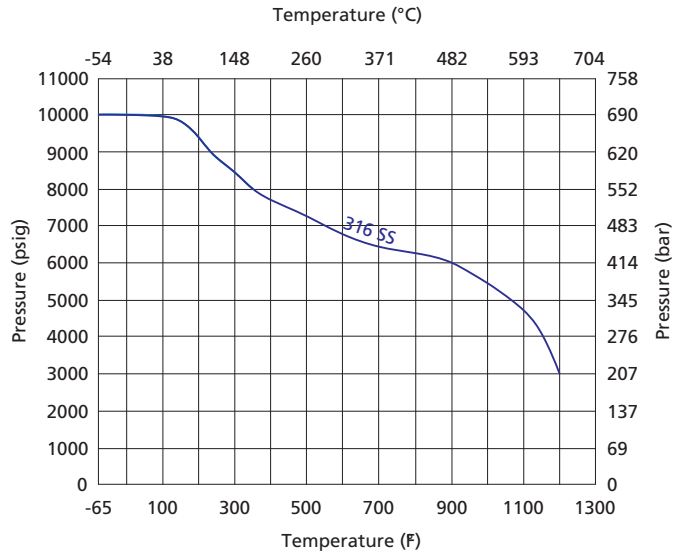

GR Series

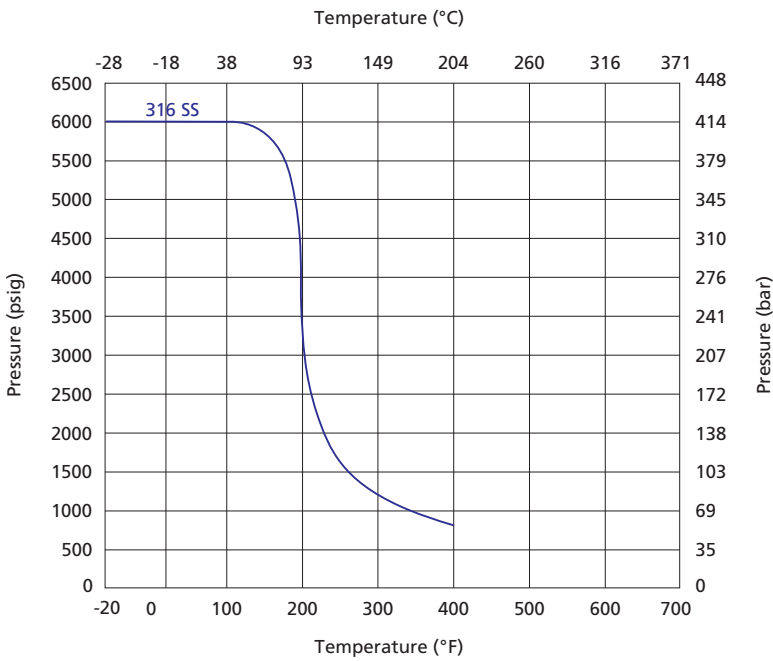

1. GV, GVH series are based on graphite packing.
2. GR series are based on PEEK seat and PTFE packing.
3. Contact FITOK Group or our authorized distributors for curve graph of GR series with Acetal seat.

Manifolds

Types and Dimensions

Standard Type

| Basic Ordering Number | Process | Instrument | Vent & Test |
|-----------------------|--------------|----------------|---|
| GV □□-NS8-FNS8 | 1/2 Male NPT | 1/2 Female NPT | 1/2 Female NPT (Bleed Valve with Plug) |
| GVH □□-NS8-FNS8 | | | |
| GR □□-NS8-FNS8 | | | |
| GV □□-NS12-FNS8 | 3/4 Male NPT | | |
| GVH □□-NS12-FNS8 | | | |
| GR □□-NS12-FNS8 | | | |

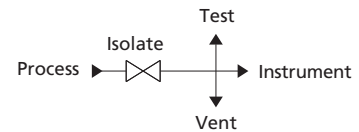
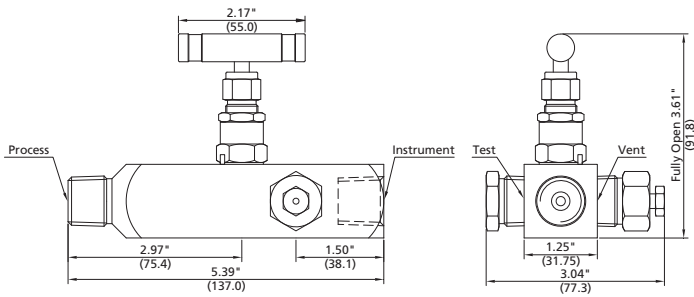

Lagging Extension Body Type

| Basic Ordering Number | Process | Instrument | Vent & Test |
|-----------------------|--------------|----------------|---|
| GV □□-NS8-FNS8-E | 1/2 Male NPT | 1/2 Female NPT | 1/2 Female NPT (Bleed Valve with Plug) |
| GVH □□-NS8-FNS8-E | | | |
| GR □□-NS8-FNS8-E | | | |

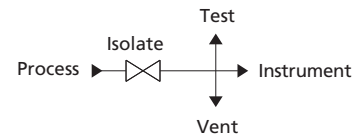
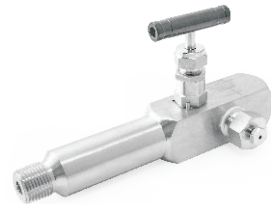
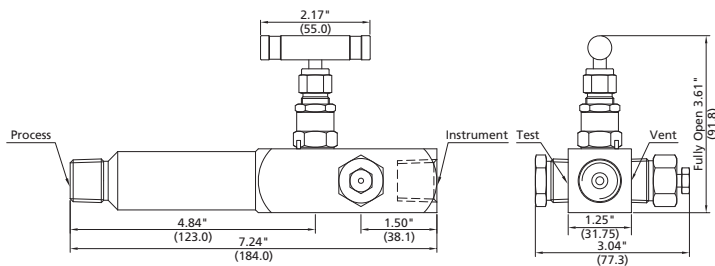

Lagging extension body is inserted through pipe insulation.

Miniature Type

| Basic Ordering Number | Process | Instrument | Vent |
|-----------------------|--------------|----------------|-----------|
| GV □□-NS8-FNS8-C | 1/2 Male NPT | 1/2 Female NPT | Vent stem |
| GVH □□-NS8-FNS8-C | | | |
| GR □□-NS8-FNS8-C | | | |

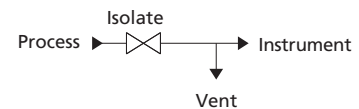
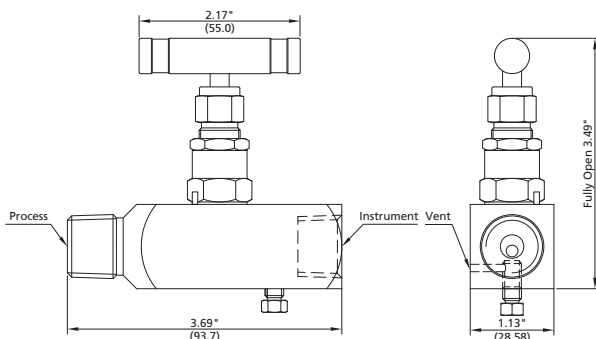

The dimensions shown are for GV series gauge valves. If you need the dimensions of GVH, GR series, please contact FITOK Group or our authorized distributors.

Ordering Number Description

GRSS - NS8 - FNS8 - CPW - GR - SF2

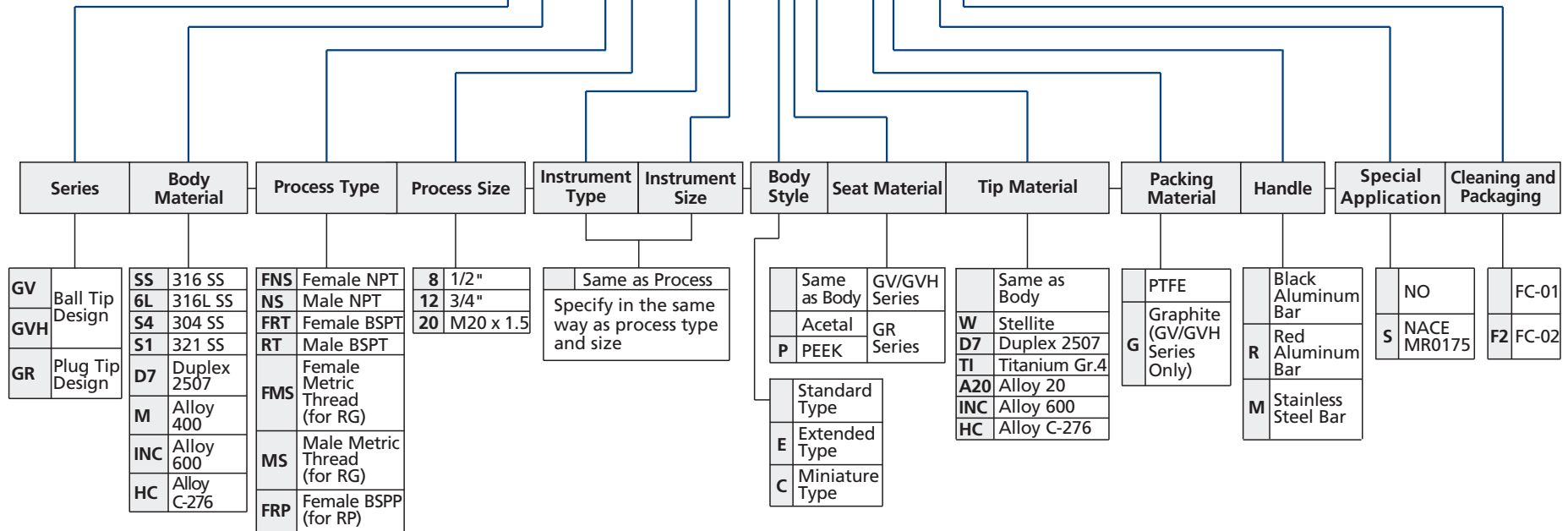

Notes:

1. Cleaning and Packaging:

FC-01: Standard cleaning and packaging for general industrial procedures.

FC-02: Special cleaning and packaging for wetted system components to ensure compliance with product cleanliness requirement as stated in ASTM G93 Level C.

2. "Ordering Number Description" is a reference to understand the combination rules of FITOK product part number.

Not all combinations are available. If you have any questions, please contact FITOK Group or our authorized distributors.

Instrumentation Manifolds

Features

- ⦿ Working pressure:
 - 2D, 2R, 3D, 3R, 5D, 5R series up to 6000 psig (414 bar)
 - 2DH, 2RH, 3DH, 3RH, 5DH, 5RH series up to 10000 psig (690 bar)
- ⦿ Working temperature:
 - PTFE packing: -65°F to 450°F (-54°C to 232°C)
 - Graphite packing: -65°F to 1200°F (-54°C to 649°C)
- ⦿ Orifice: 0.157" (4.0 mm)
- ⦿ Two-piece stem design: Upper stem threads cold rolled and lower stem hardened for high strength and smooth operation
- ⦿ Upper stem thread lubricant isolated from system media
- ⦿ Linear instead of rotary motion of the rising, non-rotating stem minimizes packing abrasion and reduces the friction between the seat and the tip
- ⦿ Safety back seating seals in fully open position
- ⦿ Steady and durable fastening of the handle by handle set screw
- ⦿ Every gauge valve leak tested at factory at rated working pressure

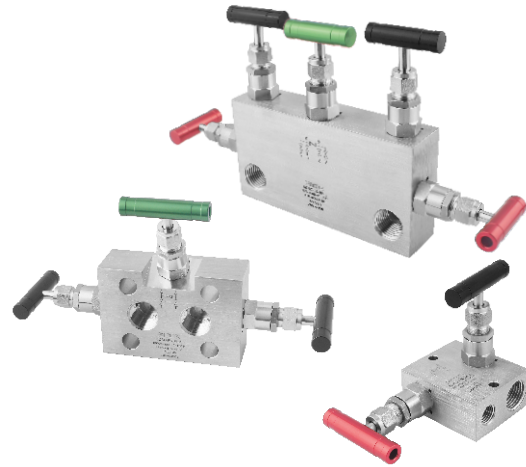

Standard Materials of Construction

| Item | Component | Valve Body Material | |
|-----------------------------------|--------------|--|-------------------------|
| | | 316 SS | Alloy C-276 |
| Material Grade/ASTM Specification | | | |
| 1 | Handle | Aluminum alloy | |
| 2 | Set Screw | Zinc-plated carbon steel | |
| 3 | Packing Bolt | 304 SS/A479 | |
| 4 | Upper Stem | 316 SS/A479 | |
| 5 | Lock Nut | Stainless steel | |
| 6 | Bonnet | <i>316 SS/A479</i> | <i>Alloy C-276/B574</i> |
| 7 | Gland | 316 SS/A479 | |
| 8 | Packing | <i>PTFE or Graphite</i> | |
| 9 | Lock Pin | Stainless steel | |
| 10 | Lower Stem | <i>Hardened 316 SS/A479</i> | <i>Alloy C-276/B574</i> |
| 11 | Body | <i>316 SS/A479</i> <i>316 SS/A182</i> | <i>Alloy C-276/B564</i> |
| | Lubricant | <i>Molybdenum disulfide-based</i> | |

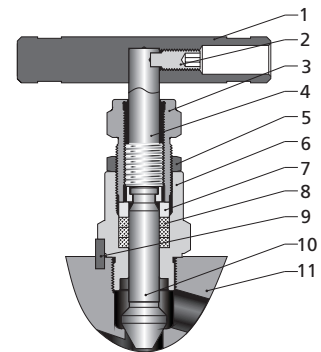

Handle colors indicate function:
 BLACK=Isolate
 RED=Vent
 GREEN=Equalize

Note: Wetted components are listed in italics.

Pressure vs. Temperature

2D, 2R, 3D, 3R, 5D, 5R Series

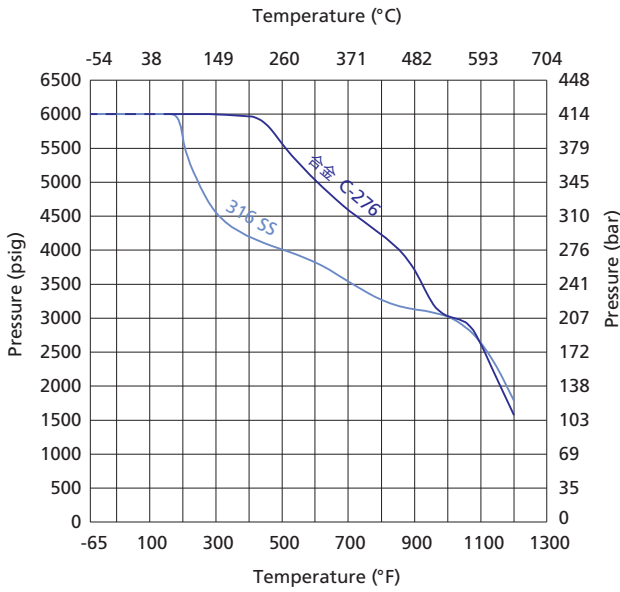

2DH, 2RH, 3DH, 3RH, 5DH, 5RH Series

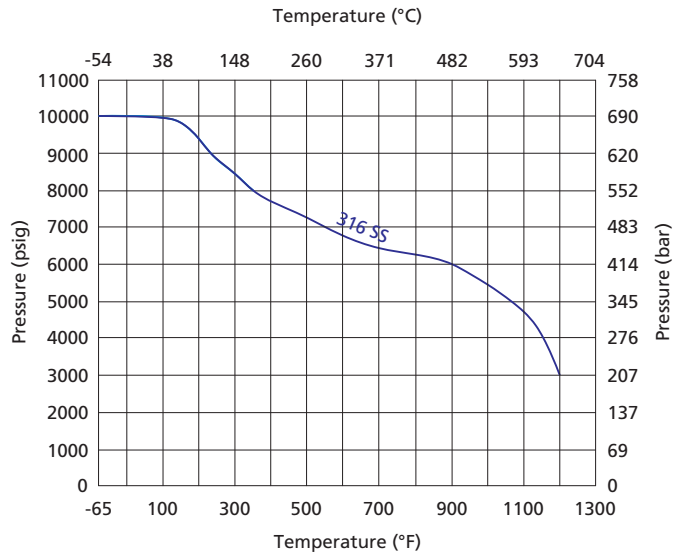

1. Based on graphite packing.
2. Contact FITOK Group or our authorized distributors for curve graph of other materials.

Design Standards

Flanges in compliance with MSS SP-99 or IEC 61518 are available. Dimensions are as follows.

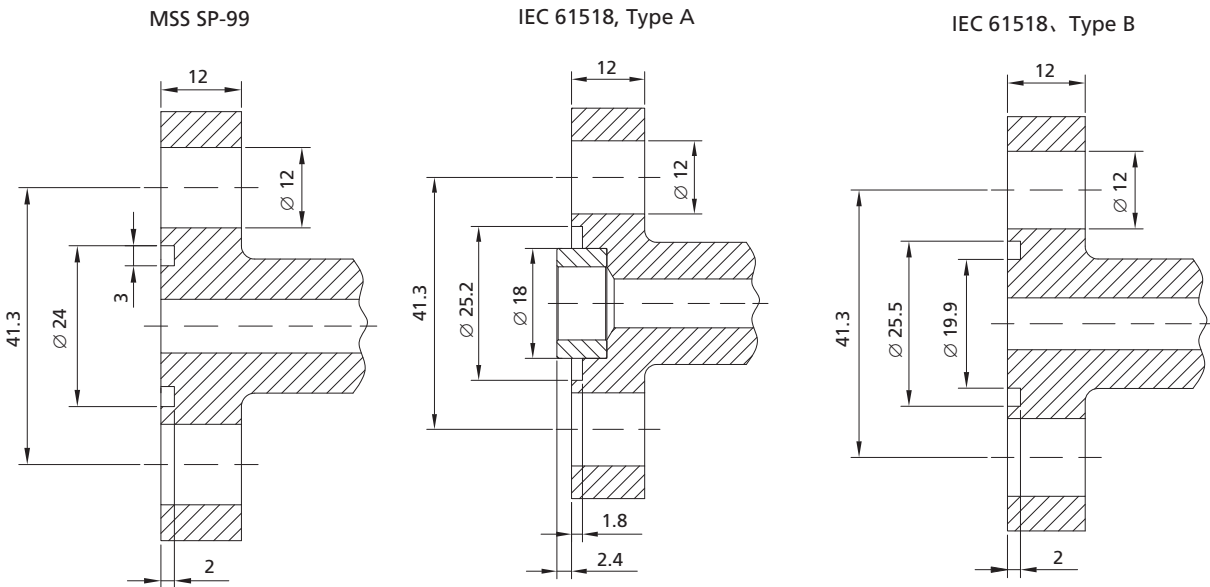

Manifolds Mounting Application

- Remote Mount Manifolds (with transmitter)
For 2R, 2RH, 3R, 3RH, 5R, 5RH series manifolds

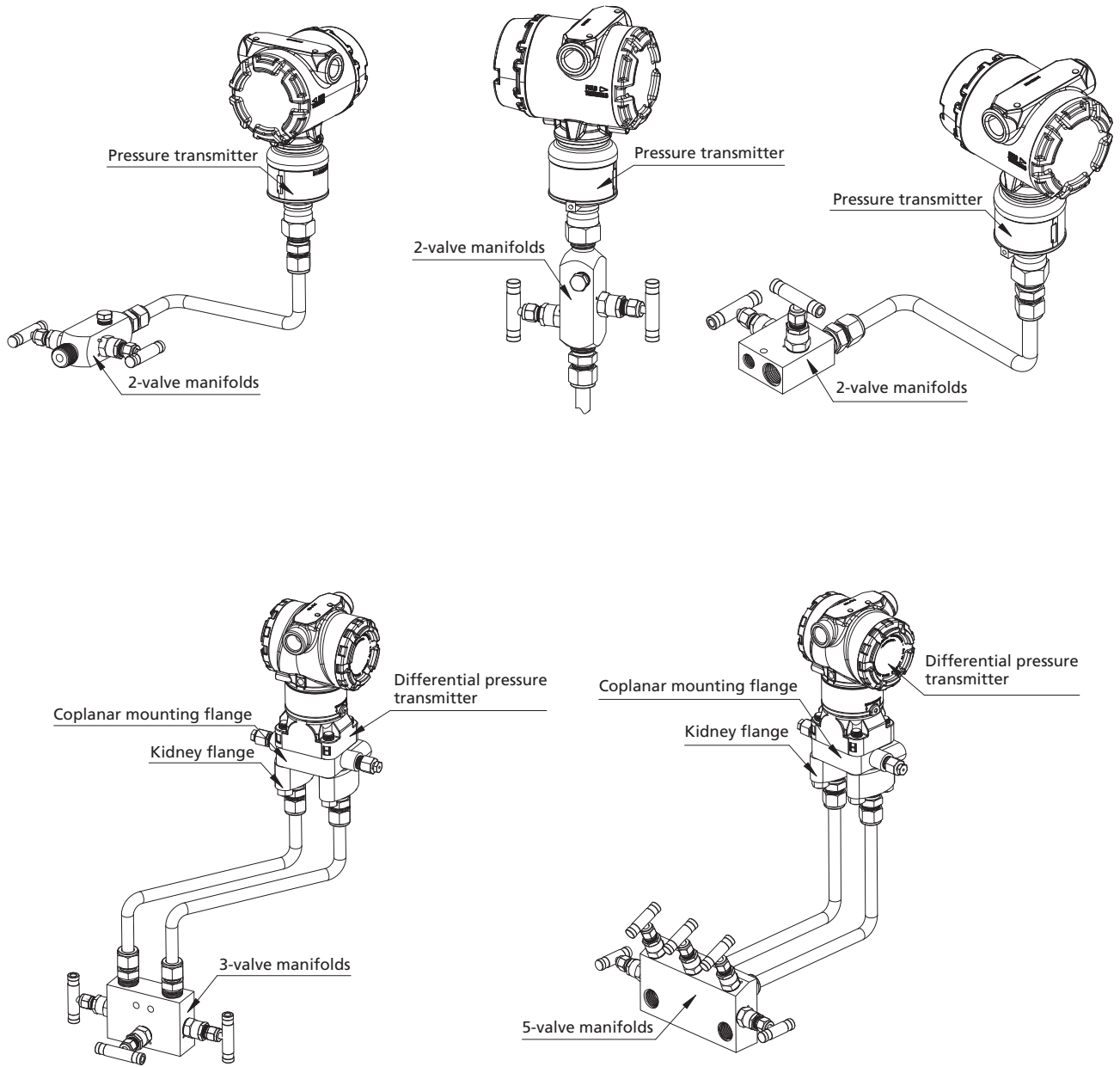

Manifolds

⊙ Direct Mount Manifolds (transmitter with coplanar mounting flange)
 For 2D, 2DH, 3D, 3DH, 5D, 5DH series layout type A and type L manifolds

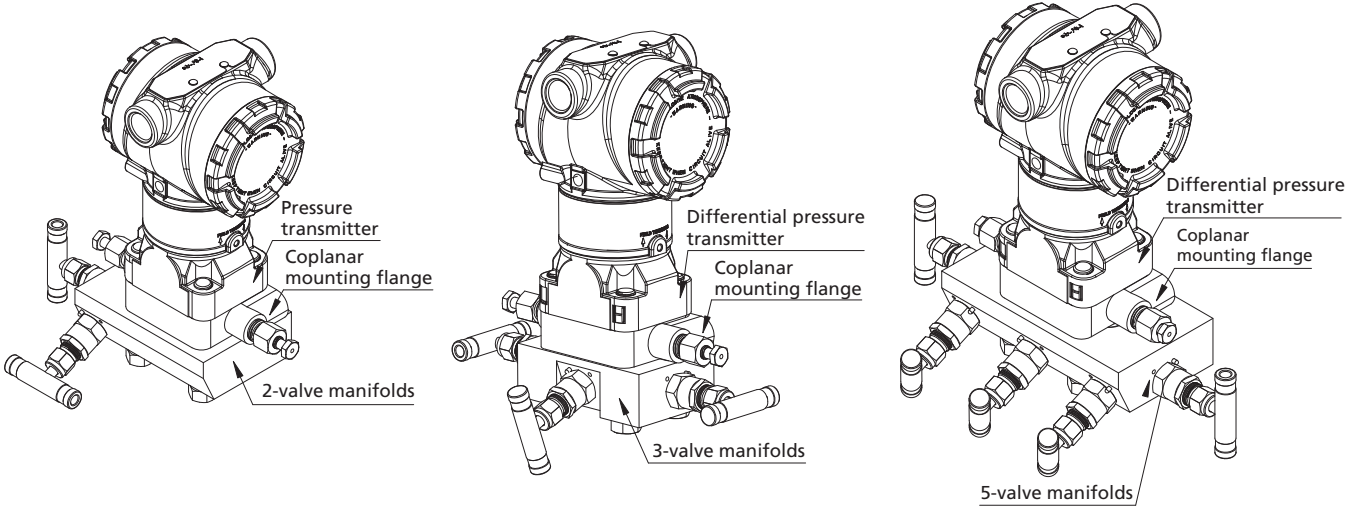

⊙ Direct Mount Manifolds (transmitter with traditional flange)
 For 2D, 2DH, 3D, 3DH, 5D, 5DH series layout type V manifolds

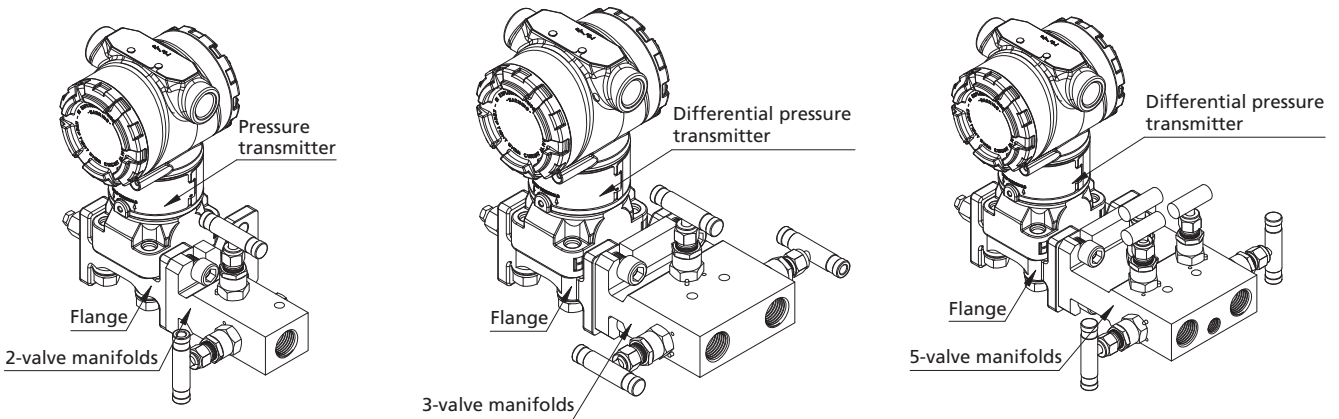

⊙ Direct Mount Manifolds (transmitter without flange)
 For integrated mount 2D55-FNS8-C, 3D55-FNS8-C-T, 5D55-FNS8-C manifolds only

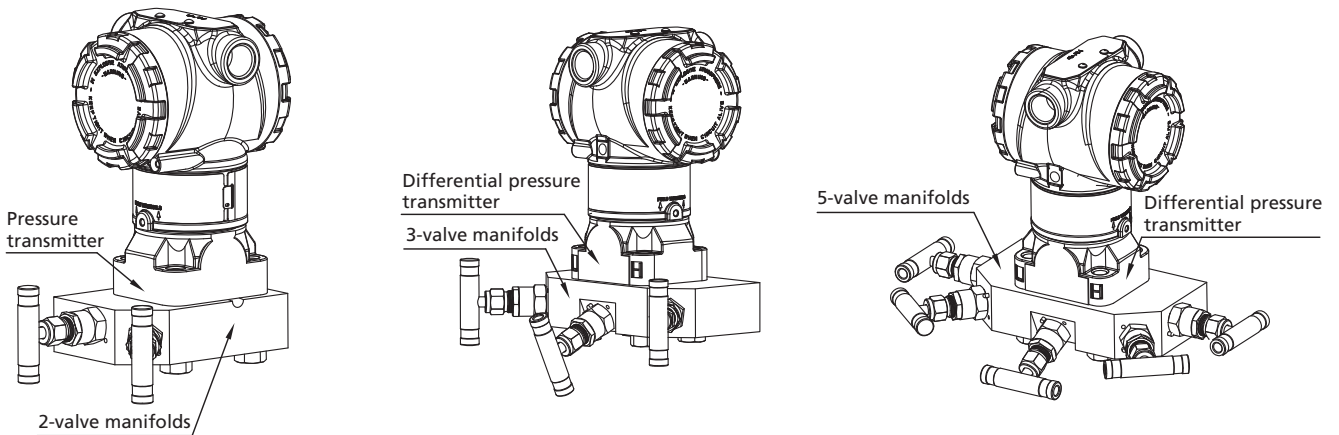

Manifolds

Types and Dimensions

Remote Mount Manifolds

☉ 2-valve manifolds

| Basic Ordering Number | Process | Instrument | Vent | |
|-----------------------|----------------|--------------|----------------|--------------------------|
| 2R□□-FNS8-NS8-H | 1/2 Female NPT | 1/2 Male NPT | 1/4 Female NPT | |
| 2RH□□-FNS8-NS8-H | | | | |
| 2R□□-NS8-H | 1/2 Male NPT | | | 1/4 Female NPT with plug |
| 2RH□□-NS8-H | | | | |
| 2R□□-NS8-H-P | | | | |

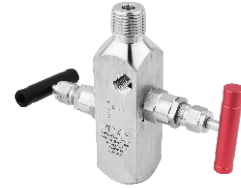

2R□□-FNS8-NS8-H

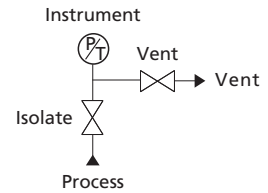
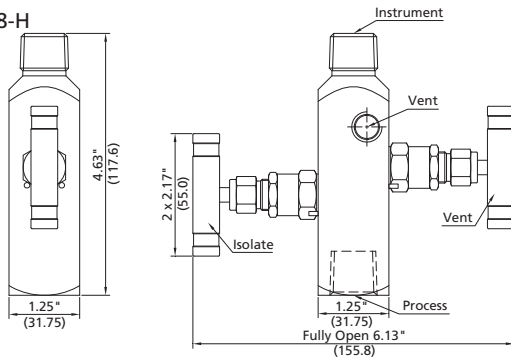

The dimensions shown are for 2R series manifolds. If you need the dimensions of 2RH series, please contact FITOK Group or our authorized distributors.

| Basic Ordering Number | Process | Instrument | Vent |
|-----------------------|--------------------------------|----------------|--------------------------------|
| 2R□□-FNS8-L | 1/2 Female NPT | 1/2 Female NPT | 1/4 Female NPT |
| 2R□□-FNS8-L-P | | | 1/4 Female NPT with Plug |
| 2R□□-NFL8-L | 1/2" Female FITOK Tube Fitting | | 1/2" Female FITOK Tube Fitting |

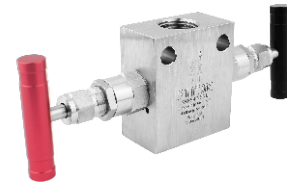

2R□□-FNS8-L

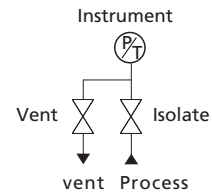
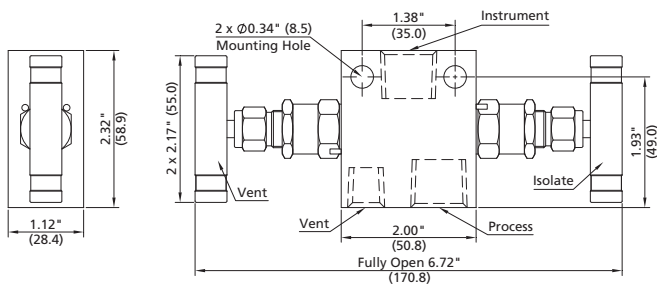

2R□□-NFL8-L

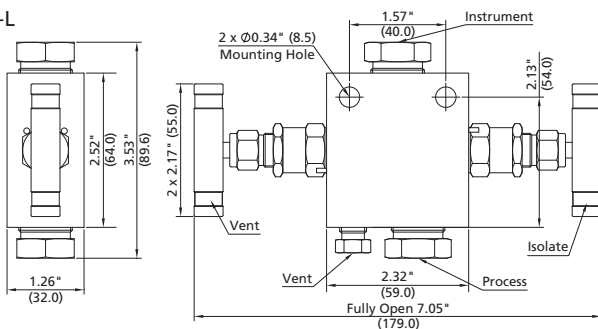

| Basic Ordering Number | Process | Instrument | Vent |
|-----------------------|--------------------------------|--------------------------------|--------------------------------|
| 2R□□-FNS8-V | 1/2 Female NPT | 1/2 Female NPT | 1/4 Female NPT |
| 2R□□-FNS8-V-P | | | 1/4 Female NPT with Plug |
| 2R□□-NFL8-V | 1/2" Female FITOK Tube Fitting | 1/2" Female FITOK Tube Fitting | 1/4" Female FITOK Tube Fitting |

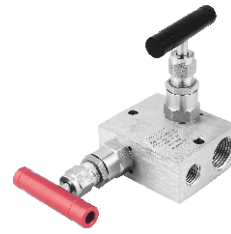

2R□□-FNS8-V

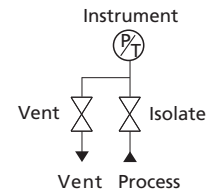
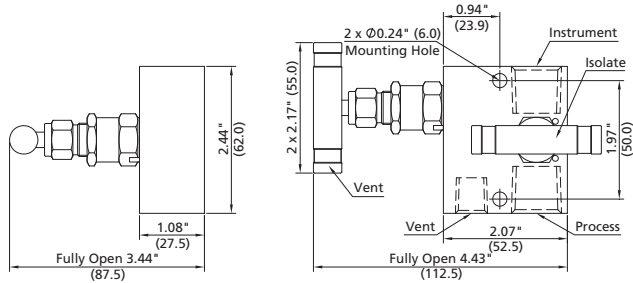

2R□□-NFL8-V

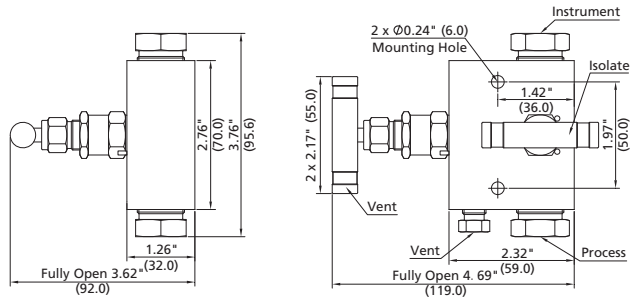

3-valve manifolds

| Basic Ordering Number | Process | Instrument | Vent |
|-----------------------|--------------------------------|--------------------------------|--------------------------|
| 3R□□-FNS8-V | 1/2 Female NPT | 1/2 Female NPT | - |
| 3RH□□-FNS8-V-P | | | 1/4 Female NPT with Plug |
| 3RH□□-FNS8-V | | | - |
| 3R□□-NFL8-V | 1/2" Female FITOK Tube Fitting | 1/2" Female FITOK Tube Fitting | - |

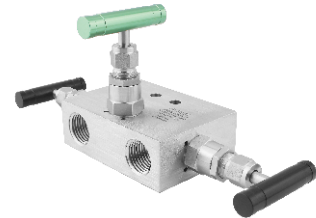

3R□□-FNS8-V-P

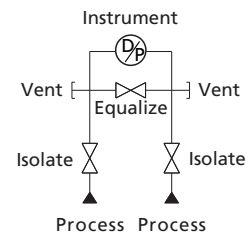
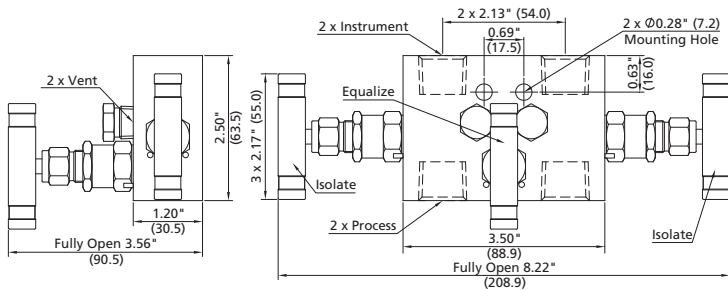

The dimensions shown are for 3R series manifolds. If you need the dimensions of 3RH series, please contact FITOK Group or our authorized distributors.

C-14 Gauge Valves and Instrumentation Manifolds

3R□□-NFL8-V

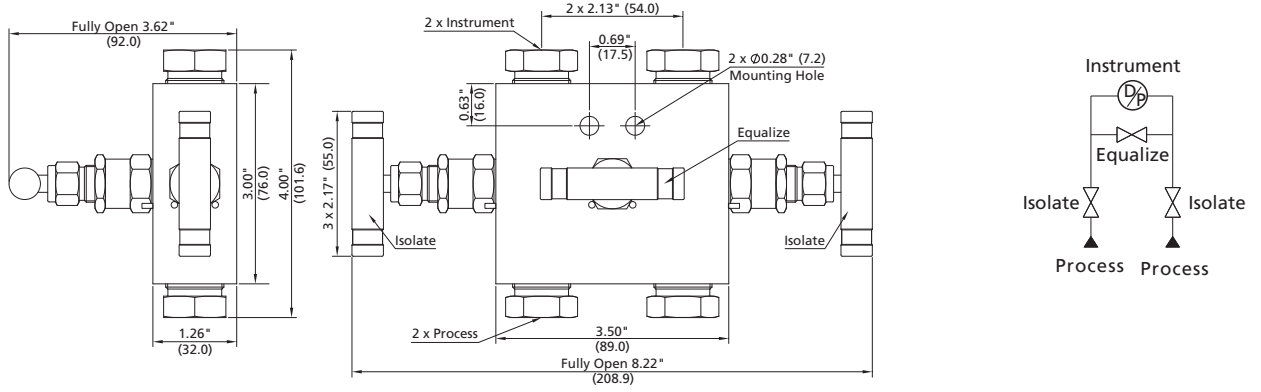

5-valve manifolds

| Basic Ordering Number | Process | Instrument | Vent |
|-----------------------|--------------------------------|--------------------------------|--------------------------|
| 5R□□-FNS8-V | 1/2 Female NPT | 1/2 Female NPT | 1/4 Female NPT |
| 5R□□-FNS8-V-P | | | 1/4 Female NPT with Plug |
| 5R□□-NFL8-V | 1/2" Female FITOK Tube Fitting | 1/2" Female FITOK Tube Fitting | 1/4 Female NPT |



5R□□-FNS8-V

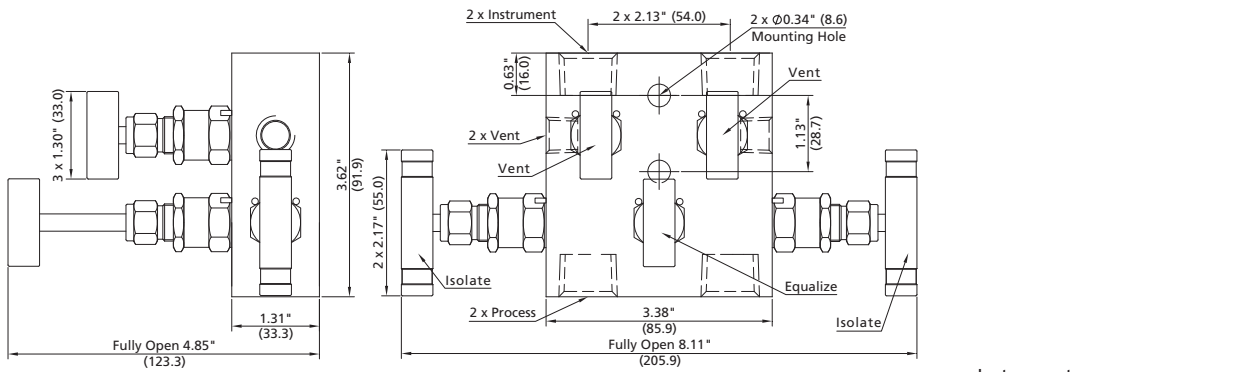

5R□□-NFL8-V

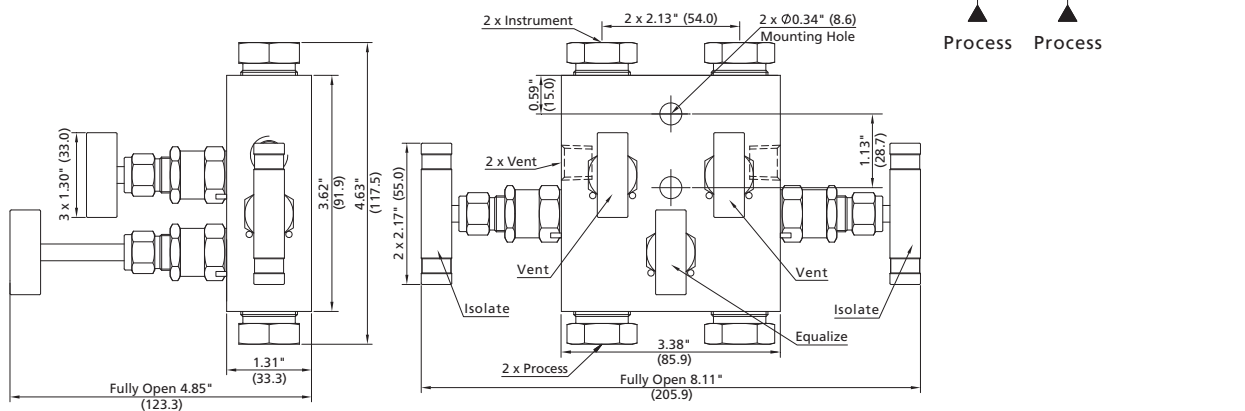

Manifolds

| Basic Ordering Number | Process | Instrument | Vent | Test |
|-----------------------|----------------|----------------|--------------------------|------|
| 5R□□-FNS8-VB | 1/2 Female NPT | 1/2 Female NPT | 1/4 Female NPT | - |
| 5R□□-FNS8-VB-P | | | 1/4 Female NPT with Plug | |
| 5R□□-FNS8-VB-E | | | 1/4 Female NPT | |

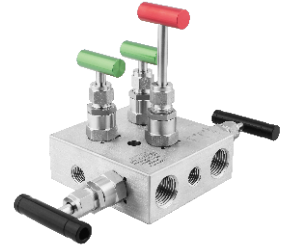

5R□□-FNS8-VB-E

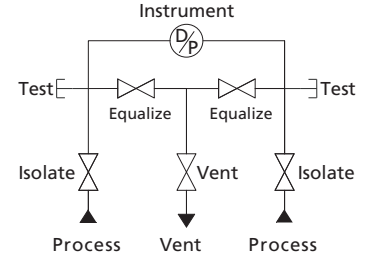
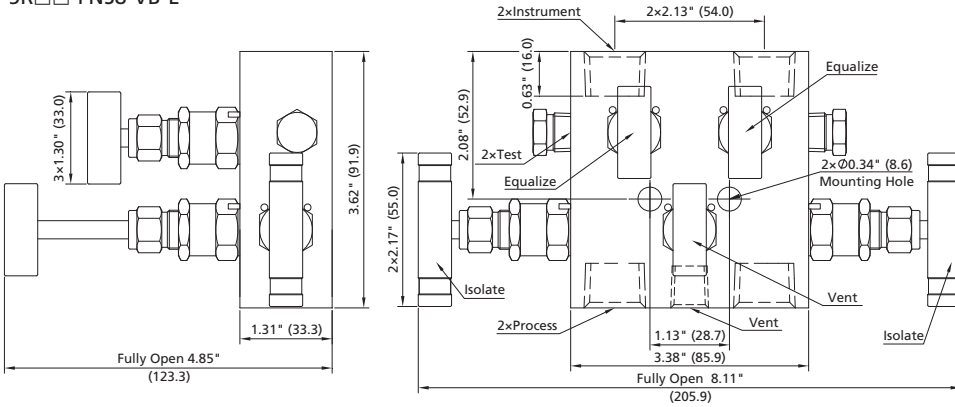

| Basic Ordering Number | Process | Instrument | Vent |
|-----------------------|----------------|----------------|--------------------------|
| 5R□□-FNS8-L | 1/2 Female NPT | 1/2 Female NPT | 1/4 Female NPT |
| 5R□□-FNS8-L-P | | | 1/4 Female NPT with Plug |
| 5RH□□-FNS8-L | | | 1/4 Female NPT |

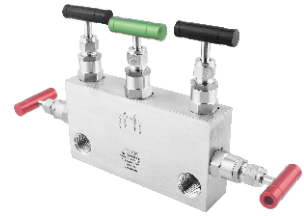

5R□□-FNS8-L

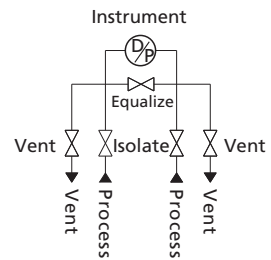
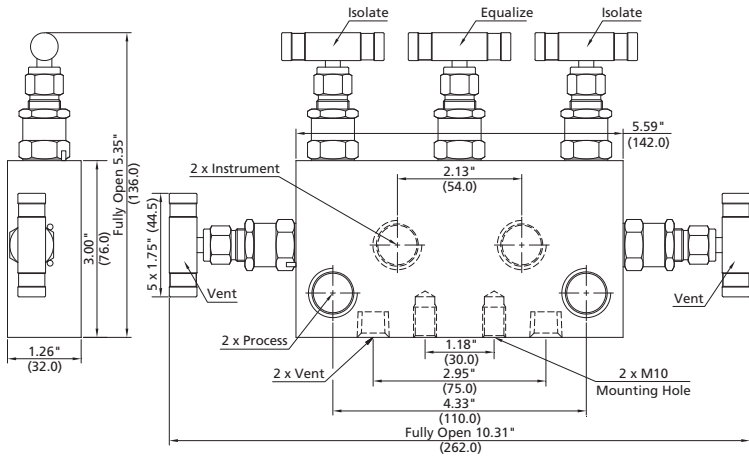

The dimensions shown are for 5R series manifolds. If you need the dimensions of 5RH series, please contact FITOK Group or our authorized distributors.

Ordering Number Description

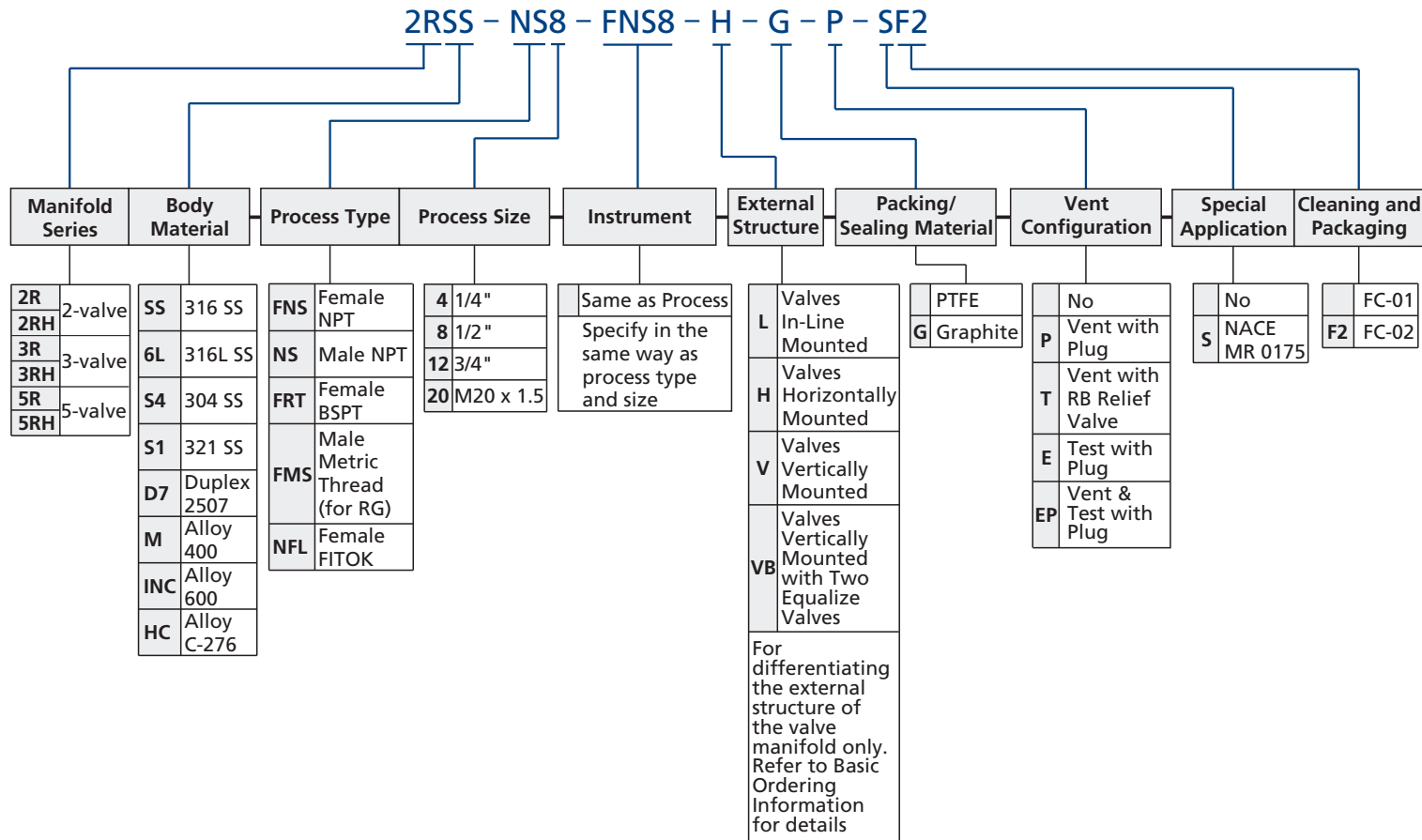

Notes:

1. Cleaning and Packaging:
 - FC-01: Standard cleaning and packaging for general industrial procedures.
 - FC-02: Special cleaning and packaging for wetted system components to ensure compliance with product cleanliness requirement as stated in ASTM G93 Level C.
2. "Ordering Number Description" is a reference to understand the combination rules of FITOK product part number. Not all combinations are available, If you have any questions, please contact FITOK Group or our authorised distributors.

Direct Mount Manifolds (transmitter with coplanar mounting flange)

This type of manifolds is designed for Rosemount® coplanar™ pressure transmitter. Manifolds for other companies' transmitters, please contact FITOK Group or our authorized distributors.

☉ 2-valve Manifolds

| Basic Ordering Number | Process | Instrument | Vent |
|-----------------------|----------------|------------------|--------------------------|
| 2D□□-FNS8-A | 1/2 Female NPT | MSS SP-99 Flange | 1/4 Female NPT |
| 2D□□-FNS8-A-P | | | 1/4 Female NPT with Plug |
| 2DH□□-FNS8-A | | | 1/4 Female NPT |



2D□□-FNS8-A

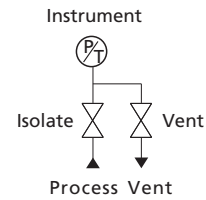
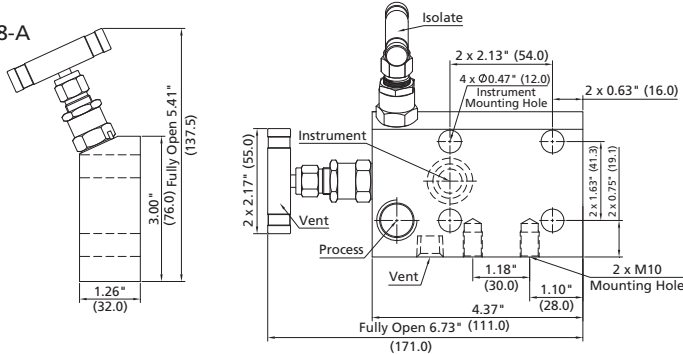

Every manifold is supplied with one PTFE sealing ring for manifold-to-instrument and four 7/16" UNF x 1.75" high tensile bolts. Dimensions shown are for 2D Series manifolds. For dimensions of 2DH Series manifolds, please contact FITOK Group or our authorized distributors.

☉ 3-valve Manifolds

| Basic Ordering Number | Process | Instrument | Vent |
|-----------------------|----------------|------------------|--------------------------|
| 3D□□-FNS8-A | 1/2 Female NPT | MSS SP-99 Flange | - |
| 3D□□-FNS8-A-P | | | 1/4 Female NPT with Plug |
| 3DH□□-FNS8-A | | | - |

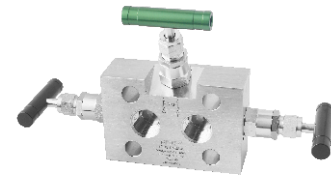

3D□□-FNS8-A

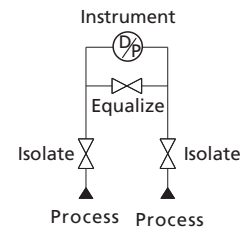
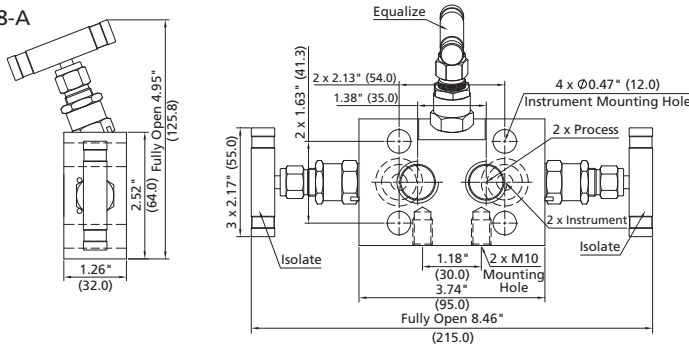

3D□□-FNS8-A-P

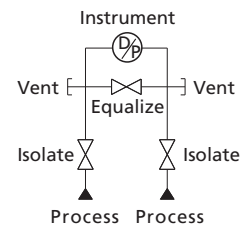
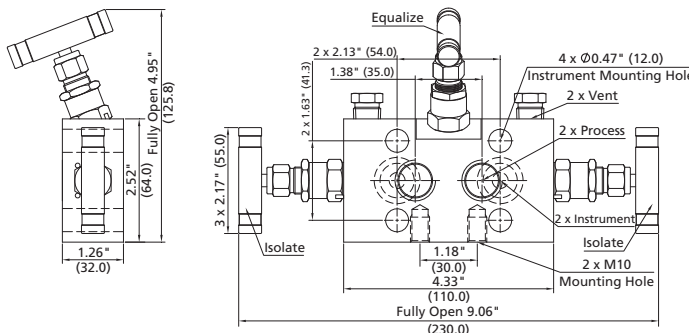

Every manifold is supplied with two PTFE sealing rings for manifold-to-instrument and four 7/16" UNF x 1.75" high tensile bolts. Dimensions shown are for 3D Series manifolds. For dimensions of 3DH Series manifolds, please contact FITOK Group or our authorized distributors.

Manifolds

C-18 Gauge Valves and Instrumentation Manifolds

5-valve Manifolds

| Basic Ordering Number | Process | Instrument | Vent |
|-----------------------|----------------|------------------|--------------------------|
| 5D□□-FNS8-A | 1/2 Female NPT | MSS SP-99 Flange | 1/4 Female NPT |
| 5D□□-FNS8-A-P | | | 1/4 Female NPT with Plug |
| 5DH□□-FNS8-A | | | 1/4 Female NPT |

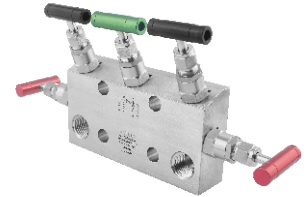

5D□□-FNS8-A

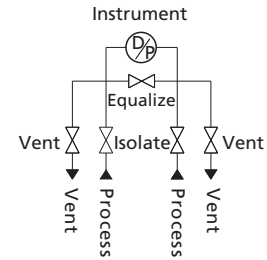
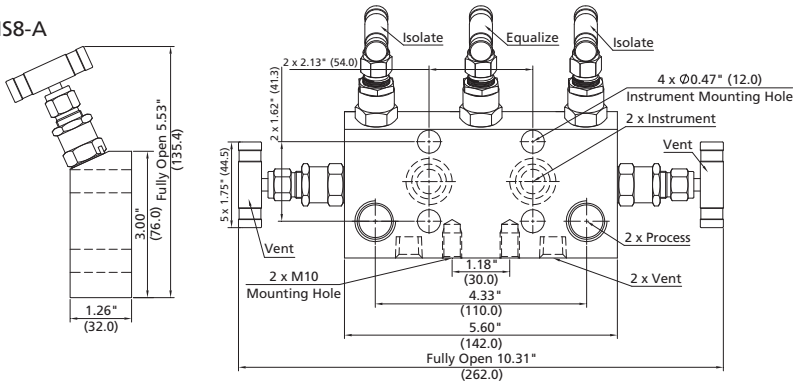

Every manifold is supplied with two PTFE sealing rings for manifold-to-instrument and four 7/16" UNF x 1.75" high tensile bolts. Dimensions shown are for 5D Series manifolds. For dimensions of 5DH Series manifolds, please contact FITOK Group or our authorized distributors.

Direct Mount Manifolds (transmitter with traditional flange)

2-valve Manifolds

| Basic Ordering Number | Process | Instrument | Vent |
|-----------------------|--------------------------------|------------------|--------------------------|
| 2D□□-FNS8-V | 1/2 Female NPT | MSS SP-99 Flange | 1/4 Female NPT |
| 2D□□-FNS8-V-P | | | 1/4 Female NPT with Plug |
| 2D□□-NFL8-V | 1/2" Female FITOK Tube Fitting | | 1/4 Female NPT |

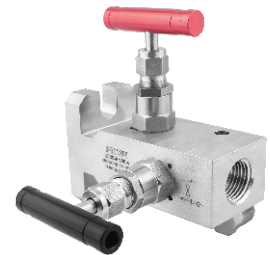

2D□□-FNS8-V

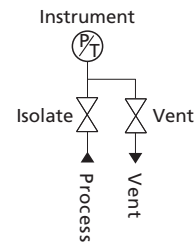
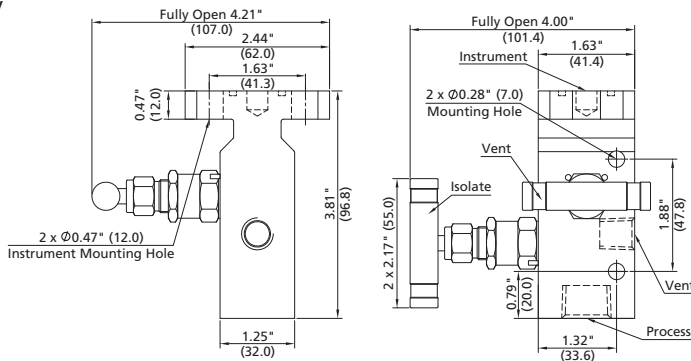

2D□□-NFL8-V

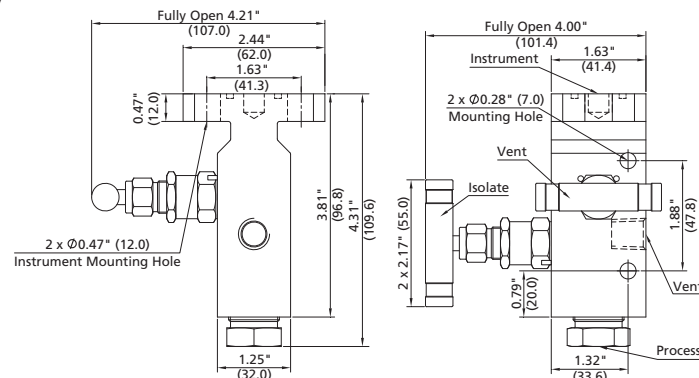

Every manifold is supplied with one PTFE sealing ring for manifold-to-instrument and two 7/16" UNF x 24mm high tensile bolts.

3-valve Manifolds

| Basic Ordering Number | Process | Instrument | Vent |
|-----------------------|--------------------------------|------------------|--------------------------|
| 3D□□-FNS8-V | 1/2 Female NPT | MSS SP-99 Flange | - |
| 3D□□-FNS8-V-P | | | 1/4 Female NPT with Plug |
| 3D□□-NFL8-V | 1/2" Female FITOK Tube Fitting | | - |

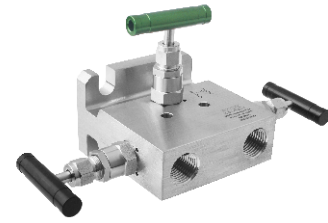

3D□□-FNS8-V-P

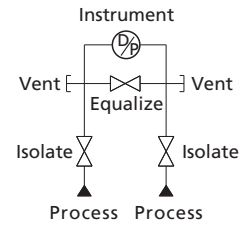
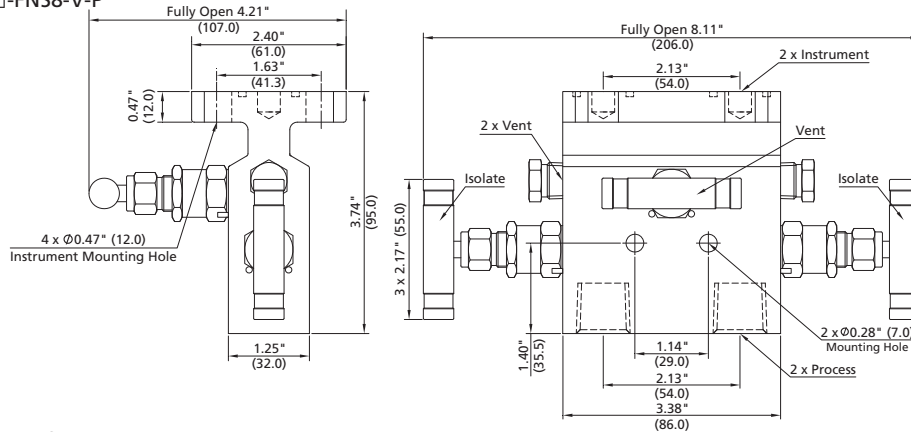

3D□□-NFL8-V

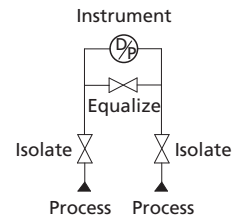
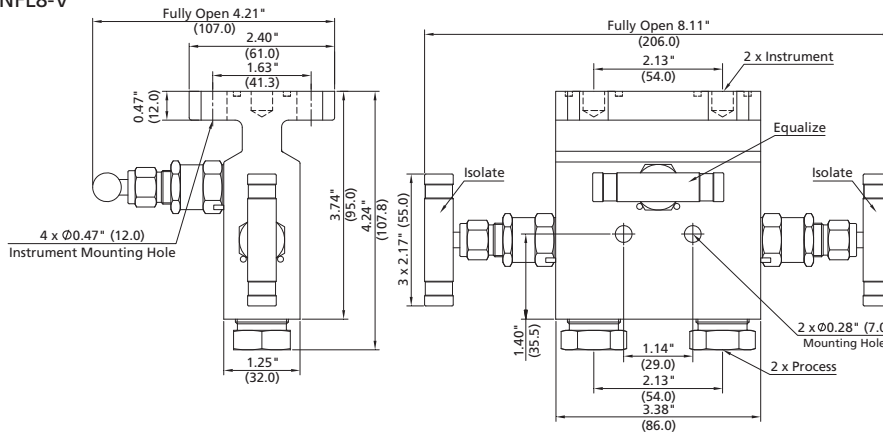

Every manifold is supplied with two PTFE sealing rings for manifold-to-instrument and four 7/16" UNF x 24mm high tensile bolts.

| Basic Ordering Number | Process | Instrument | Vent |
|-----------------------|---------|------------------|--------------------------|
| 3D□□-F-V | Flange | MSS SP-99 Flange | - |
| 3D□□-F-V-P | | | 1/4 Female NPT with Plug |

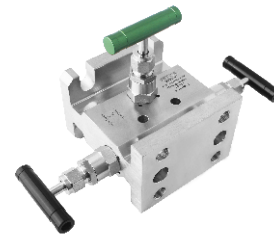

3D□□-F-V

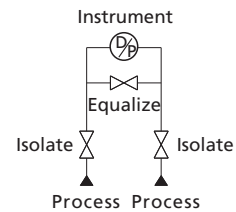
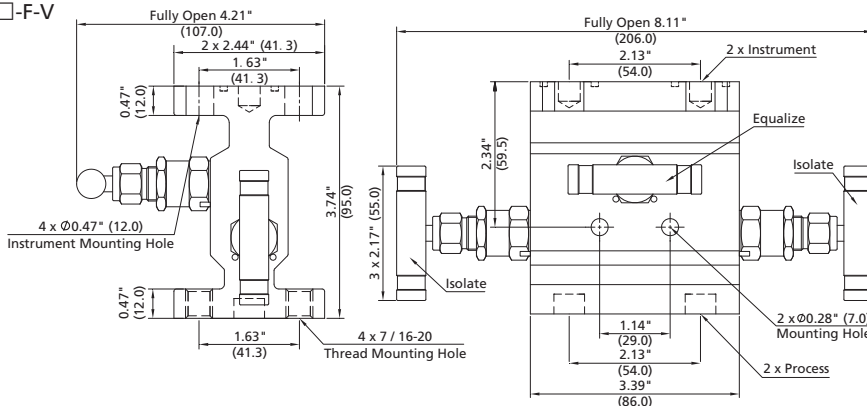

Every manifold is supplied with two PTFE sealing rings for manifold-to-instrument and four 7/16" UNF x 24mm high tensile bolts.

C-20 Gauge Valves and Instrumentation Manifolds

5-valve Manifolds

| Basic Ordering Number | Process | Instrument | Vent |
|-----------------------|--------------------------------|------------------|--------------------------|
| 5D□□-FNS8-V | 1/2 Female NPT | MSS SP-99 Flange | 1/4 Female NPT |
| 5D□□-FNS8-V-P | | | 1/4 Female NPT with Plug |
| 5D□□-NFL8-V | 1/2" Female FITOK Tube Fitting | | 1/4 Female NPT |

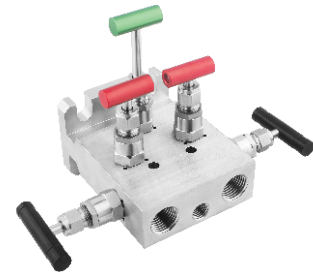

5D□□-FNS8-V

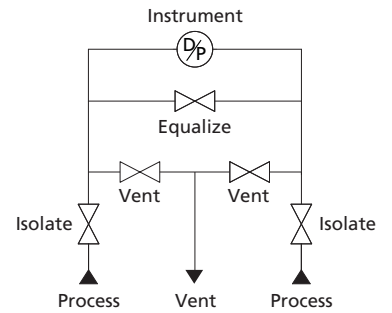
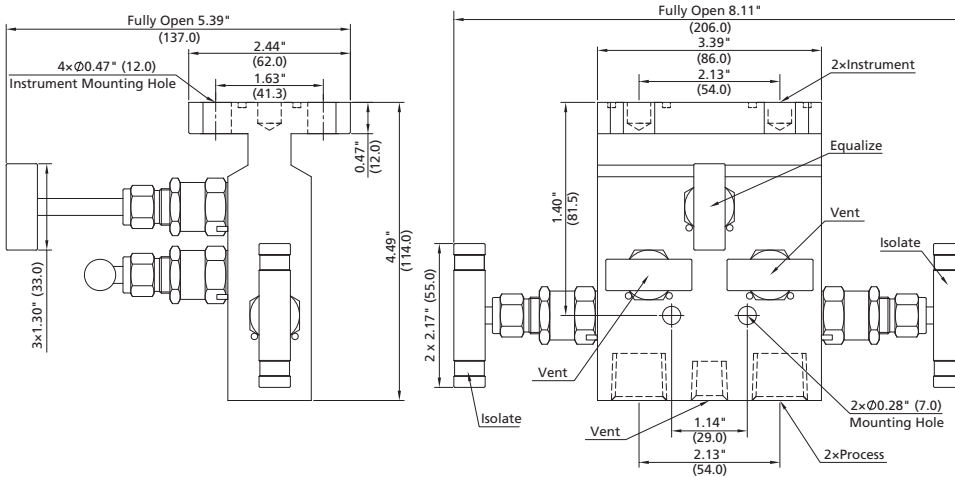

5D□□-NFL8-V

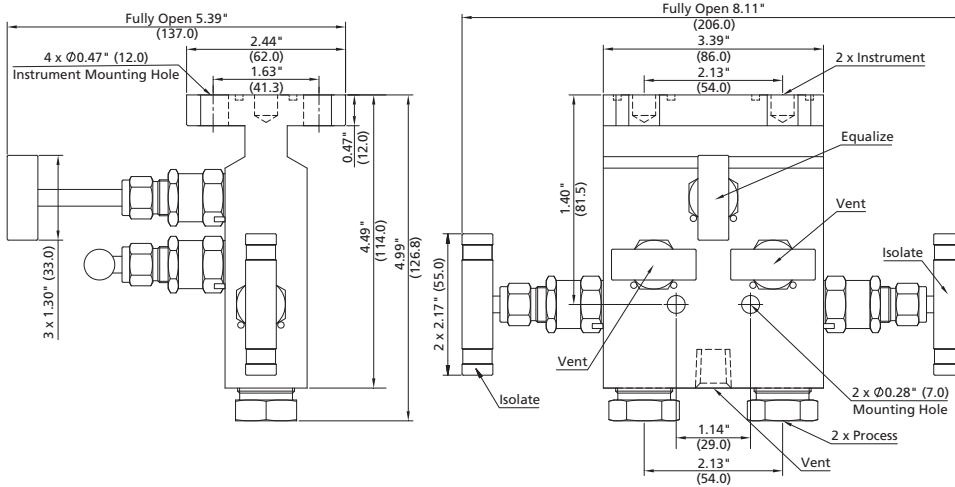

Every manifold is supplied with two PTFE sealing rings for manifold-to-instrument and four 7/16" UNF x 24mm high tensile bolts.

Manifolds

| Basic Ordering Number | Process | Instrument | Vent | Test |
|-----------------------|----------------|------------------|--------------------------|------|
| 5D□□-FNS8-VB | 1/2 Female NPT | MSS SP-99 Flange | 1/4 Female NPT | - |
| 5D□□-FNS8-VB-P | | | 1/4 Female NPT with Plug | |
| 5D□□-FNS8-VB-E | | | 1/4 Female NPT | |

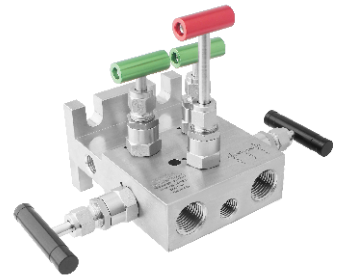

5D□□-FNS8-VB-E

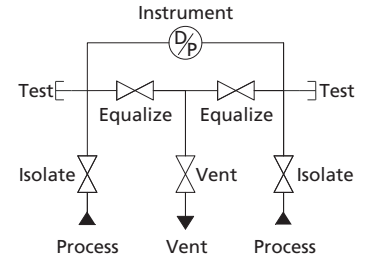
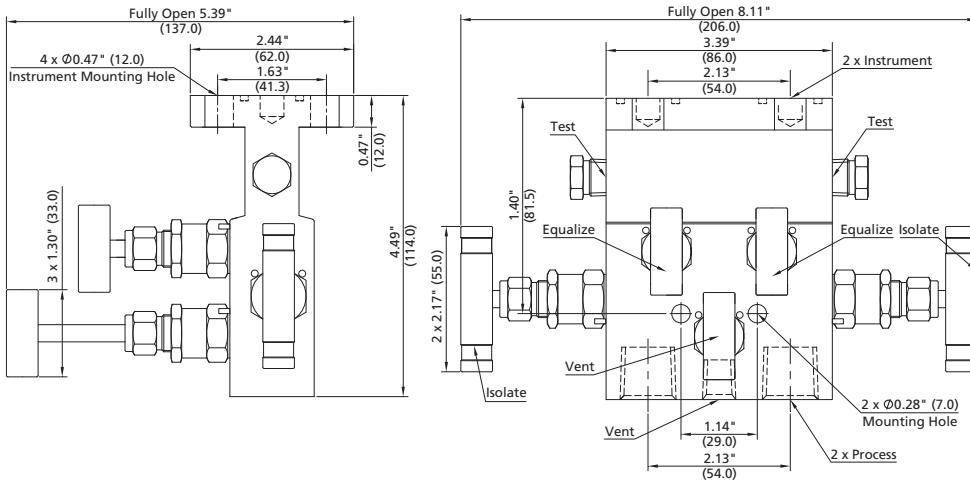

| Basic Ordering Number | Process | Instrument | Vent | Test |
|-----------------------|---------|------------------|--------------------------|------|
| 5D□□-F-VB | Flange | MSS SP-99 Flange | 1/4 Female NPT | - |
| 5D□□-F-VB-P | | | 1/4 Female NPT with Plug | |
| 5D□□-F-VB-E | | | 1/4 Female NPT | |

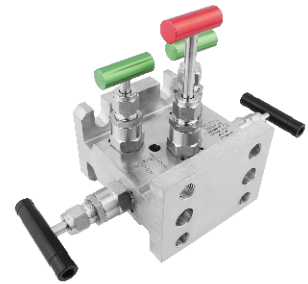

5D□□-F-VB-E

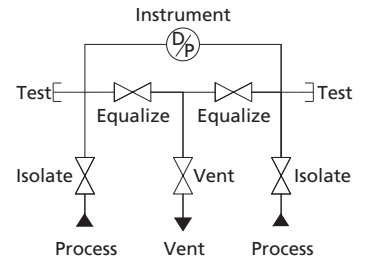
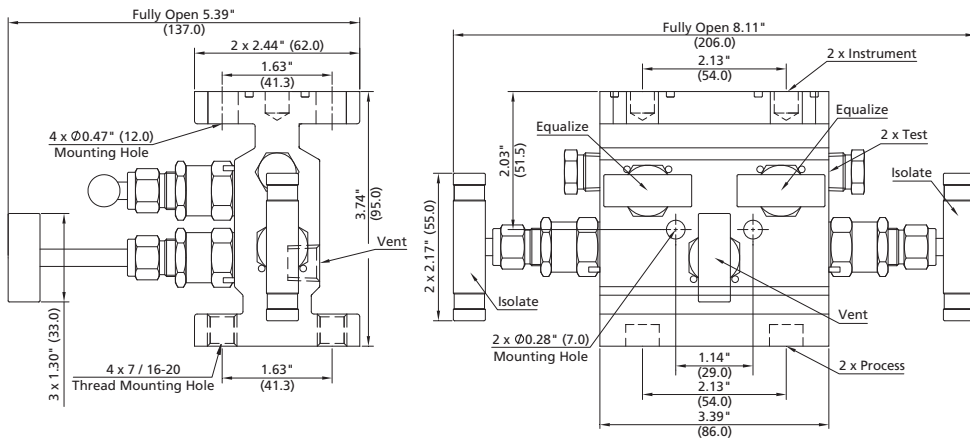

Manifolds

Every manifold is supplied with two PTFE sealing rings for manifold-to-instrument and four 7/16" UNF x 24mm high tensile bolts.

Ordering Number Description

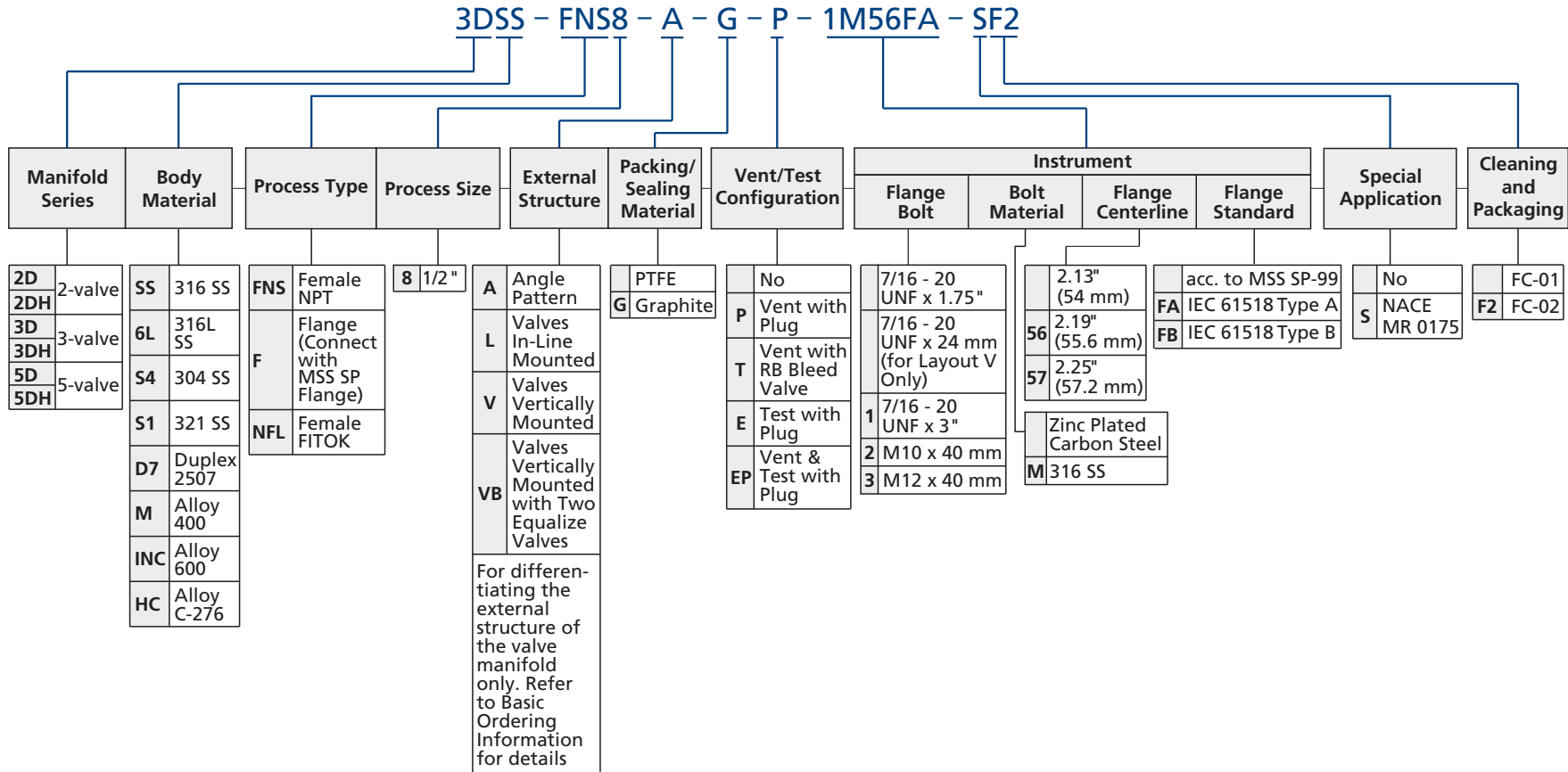

Notes:

1. Standard manifold instrument is flange (according to MSS SP-99), flange distance (center-to-center) is 2.13" (54 mm).
Distance of 2.19" (55.6 mm) suitable for transmitters of range 6, 7 and 1151.
Distance of 2.25" (57.2 mm) transmitters of range 8 and 1151.
2. Cleaning and Packaging:
FC-01: Standard cleaning and packaging for general industrial procedures.
FC-02: Special cleaning and packaging for wetted system components to ensure compliance with product cleanliness requirement as stated in ASTM G93 Level C.
3. "Ordering Number Description" is a reference to understand the combination rules of FITOK product part number. Not all combinations are available. If you have any questions, please contact FITOK Group or our authorised distributors.

Direct Mount Manifolds (transmitter without flange)

Specifically designed for assembly to Rosemount® coplanar™ pressure transmitters (including 3051C, 3051S, 2024 and 3095 models). Each manifold is included with: 4 pcs 7/16" UNF x 2" high tensile bolts. Assembles directly to transmitter.

2-valve manifolds

| Basic Ordering Number | Process | Instrument | Vent |
|-----------------------|----------------|------------|--------------------------|
| 2D□□-FNS8-C | 1/2 Female NPT | Flange | 1/4 Female NPT |
| 2D□□-FNS8-C-P | | | 1/4 Female NPT with Plug |
| 2DH□□-FNS8-C | | | 1/4 Female NPT |

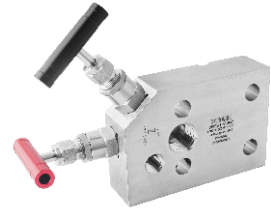

2D□□-FNS8-C

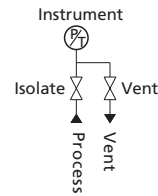
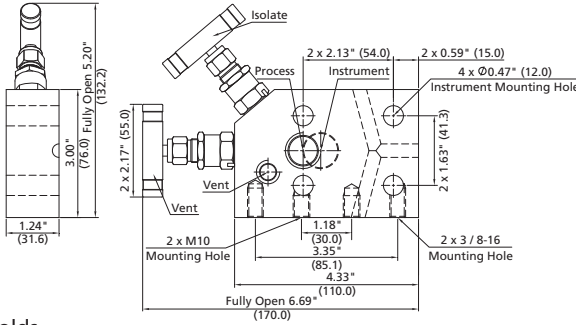

3-valve manifolds

| Basic Ordering Number | Process | Instrument | Vent |
|-----------------------|----------------|------------|----------------------------------|
| 3D□□-FNS8-C-T | 1/2 Female NPT | Flange | 1/4 Female NPT |
| 3DH□□-FNS8-C-T | | | 1/4 Female NPT with Relief Valve |

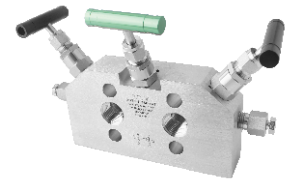

3D□□-FNS8-C-T

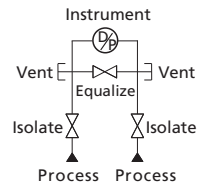
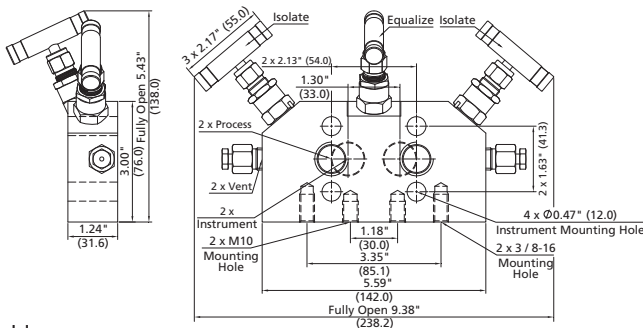

5-valve manifolds

| Basic Ordering Number | Process | Instrument | Vent |
|-----------------------|----------------|------------|--------------------------|
| 5D□□-FNS8-C | 1/2 Female NPT | Flange | 1/4 Female NPT |
| 5D□□-FNS8-C-P | | | 1/4 Female NPT with Plug |
| 5DH□□-FNS8-C | | | 1/4 Female NPT |

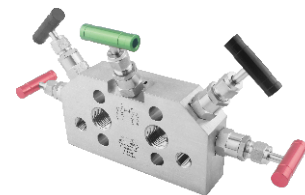

5D□□-FNS8-C

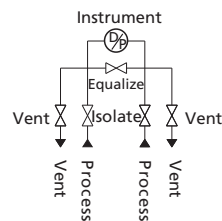
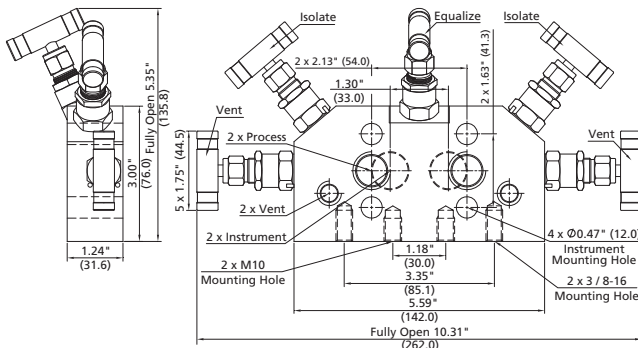

Dimensions shown are for 2D/3D/5D Series manifolds. For dimensions of 2DH/3DH/5DH Series manifolds, please contact FITOK Group or our authorized distributors.

Accessories

Manifold Mounting Bracket Kit

The integral assembly includes: bracket, U-bolts, bolts, gaskets, nuts

| Basic Ordering Number | Mounting Manifold |
|-----------------------|-------------------------------------|
| SS-M2P-2BK | 2R□□-XX-A, 2R□□-XX-L, 2RH□□-XX-A |
| SS-M2P-2BK-50 | 2R□□-XX-V |
| SS-M2P-2BK-17.5 | 3R□□-XX-V |
| SS-M2P-2BK-28.7 | 5R□□-XX-VB, 5R□□-XX-V |

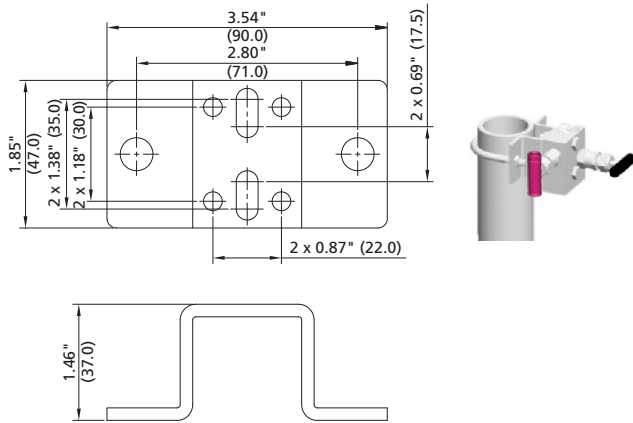

Dimensions shown are for manifold SS-M2P-2BK. For dimensions of other manifolds, please contact FITOK Group or our authorized distributors.

| Basic Ordering Number | Mounting Manifold |
|-----------------------|--|
| SS-M2P-4BK | 2D□□-XX-A, 2D□□-XX-L, 3D□□-XX-A, 3D□□-XX-L, 5D□□-XX-A, 5D□□-XX-AB, 5R□□-XX-L, 5R□□-XX-AB, 2DH□□-XX-A, 3DH□□-XX-A, 5DH□□-XX-A, 5RH□□-XX-AB |

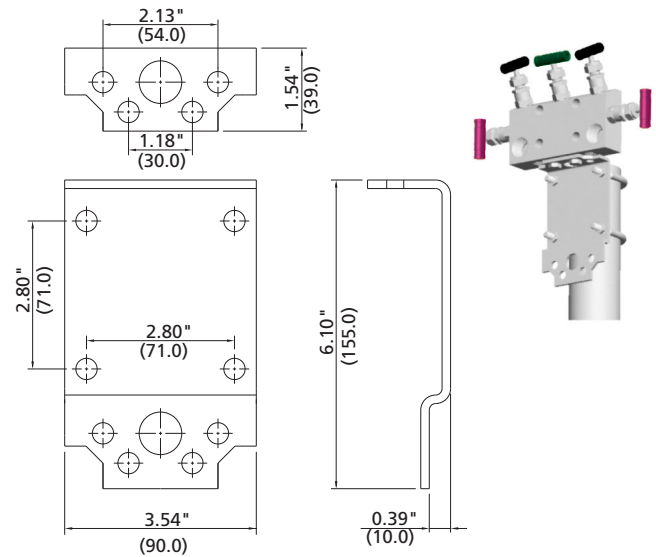

| Basic Ordering Number | Mounting Manifold |
|-----------------------|---|
| SS-M2P-6BK | 2D□□-XX-C, 3D□□-XX-C, 5D□□-XX-C, 2DH□□-XX-C, 3DH□□-XX-C, 5DH□□-XX-C |

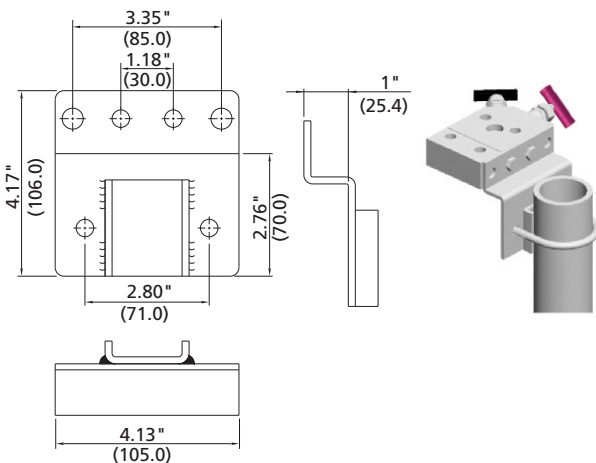

| Basic Ordering Number | Mounting Manifold |
|-----------------------|---|
| SS-M2P-8BK | 2D□□-XX-A, D□□-XX-A, 3D□□-XX-L, 2D□□-XX-C, 3D□□-XX-C, 5D□□-XX-C |

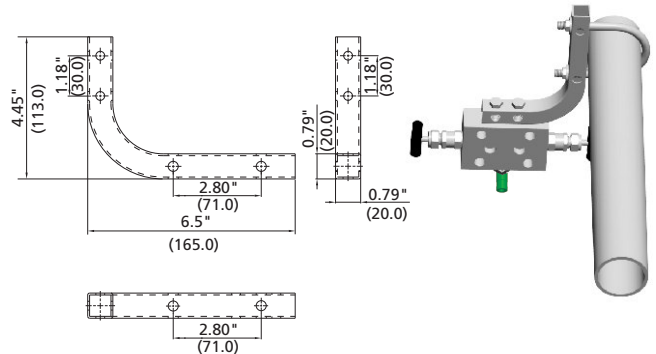

For more installation information regarding other manifolds, please contact FITOK Group or our authorized distributors.

Kidney Flanges and Eccentric Flanges

Features

- ⦿ Working temperature:
PTFE: -65°F to 450°F (-54°C to 232°C)
Graphite: -65°F to 1200°F (-54°C to 649°C)
- ⦿ integrally forged body
- ⦿ Standard material: A182 F316
- ⦿ The process connection of transmitter can be changed to other connection types

Types and Dimensions

KF Series

| Basic Ordering Number | Connection Type and Size | Dimension in. (mm) |
|-----------------------|--------------------------|--------------------|
| | | A |
| SS-KF-FNS4 | 1/4 Female FITOK | 1.10 (28.0) |
| SS-KF-FNS8 | 1/2 Female FITOK | 1.10 (28.0) |
| SS-KF-FL8 | 1/2 FITOK | 2.48 (63.0) |
| SS-KF-PB8 | 1/2 PB | 2.10 (53.3) |

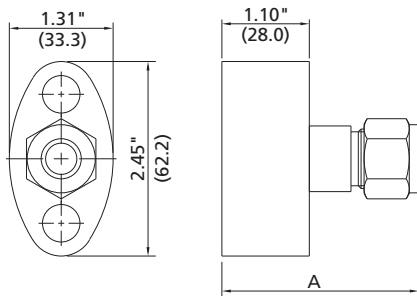

EF Series (Eccentric)

| Basic Ordering Number | Connection Type and Size | Dimension in. (mm) |
|-----------------------|--------------------------|--------------------|
| | | A |
| SS-EF-FNS4 | 1/4 Female FITOK | 1.10 (28) |
| SS-EF-FNS8 | 1/2 Female FITOK | 1.10 (28) |
| SS-EF-FL8 | 1/2 FITOK | 2.48 (63) |
| SS-EF-PB8 | 1/2 PB | 2.10 (53.3) |

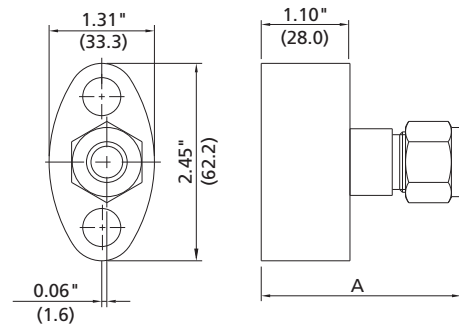

1. A kidney flange set contains a kidney flange, a PTFE flange seal ring and two 7/16 - 20 UNF high tensile bolts.
2. A whole eccentric flange set contains two eccentric flanges, two PTFE flange seal rings and four 7/16 - 20 UNF high tensile bolts.
3. The standard flange seal material is PTFE, graphite is an option. To order graphite flange seal material, add "- G" as a suffix.
4. A variety of center line distances can be obtained by using various combinations of kidney flanges sets: 2.00" (50.8 mm), 2.13" (54.0 mm) and 2.25" (57.2 mm).

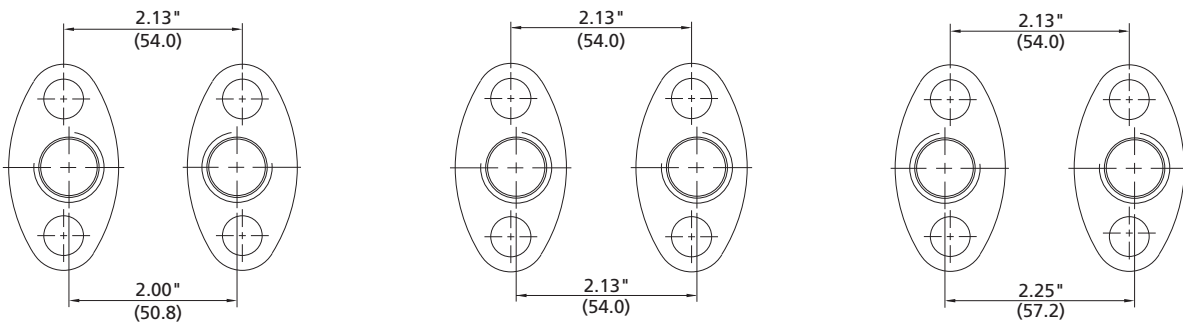

info@fitok.com
www.fitok.com

FK-IC-GV-12-EN-240509