

General Tied Diaphragm Regulators

RSGC Series

Introduction

RSGC Series General Tied Diaphragm Regulators feature a single-stage pressure reduction design. The tied diaphragm construction provides positive shutoff. The poppet spring design improves flow characteristics, making these regulators suitable for low flow, high purity, and ultra high purity applications.



Features

- ⦿ Lightweight, compact design
- ⦿ Lift poppet and diaphragm are made of Alloy 22, offering excellent corrosion resistance
- ⦿ Metal-to-metal seal between valve body and diaphragm ensures reliable sealing performance
- ⦿ Tied diaphragm construction offers positive shutoff for added safety
- ⦿ Reinforced diaphragm improves sealing performance and extends service life
- ⦿ Bonnet with a captured vent port allows media to be vented to a designated location in the event of diaphragm rupture

Technical Data

Port Size		1/4", 3/8" or 1/2"	
Max. Working Pressure		3500 psig (241 bar)	
Outlet Pressure Range		0 ~ 30 psig (0 ~ 2.1 bar)	
		0 ~ 60 psig (0 ~ 4.2 bar)	
		0 ~ 100 psig (0 ~ 6.9 bar)	
Flow Coefficient (Cv)		0.09	
Working Temperature ^①		PTFE: -40 ~ 160 °F (-40 ~ 71 °C)	
		Polyimide: 14 ~ 194 °F (-10 ~ 90 °C)	
SPE (Supply Pressure Effect)		0.75 psig per 100 psig source pressure change	
Leak Rate (Helium)	External	Inboard	≤2×10 ⁻¹⁰ std·cm ³ /s
		Outboard	≤2×10 ⁻⁹ std·cm ³ /s
	Internal	≤1×10 ⁻⁹ std·cm ³ /s	

① For the working temperature of products equipped with a pressure gauge, please refer to the catalog for [Pressure Gauges](#).

Flow Data

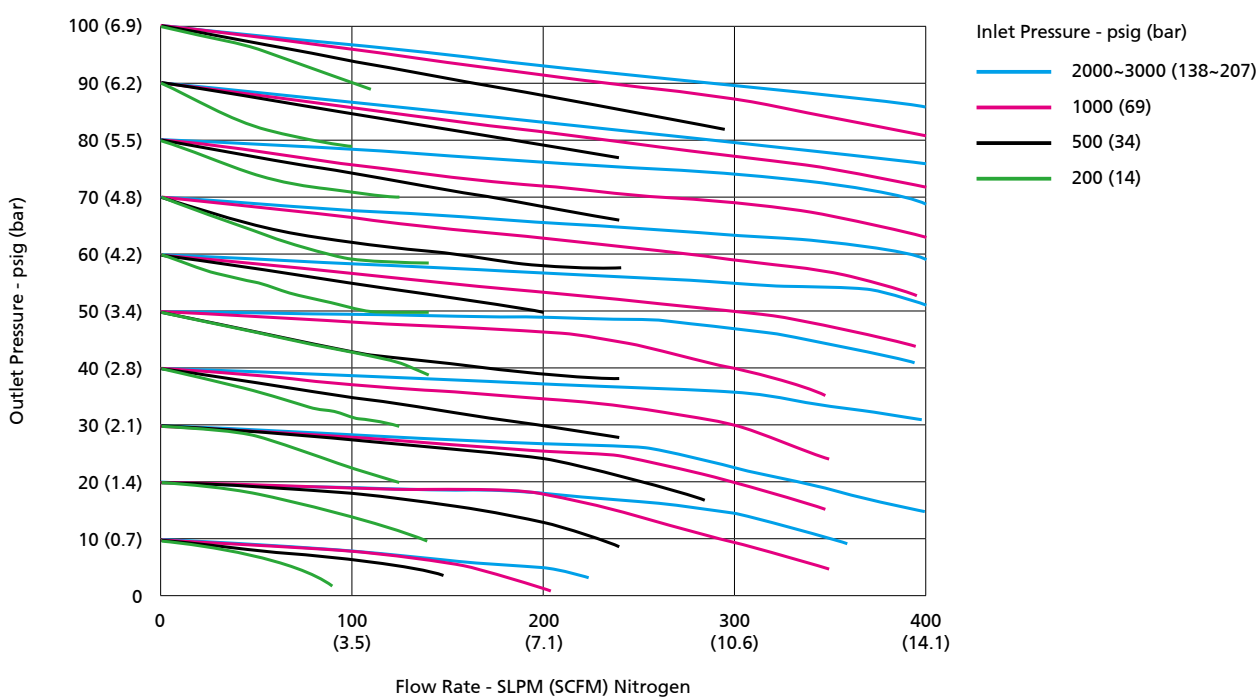
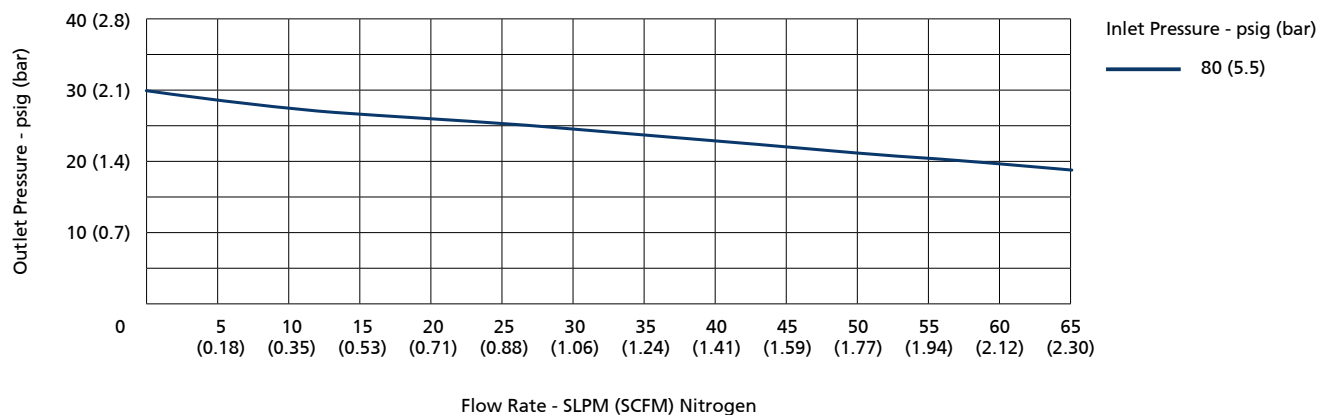

Process Specification

Item	Process Specification	Special Cleaning and Packaging Process (FC-02)	Ultra High Purity Process (FC-03)
Material		316L SS	316L SS, 316L SS VAR
Wetted Surface Roughness		Ra 10 $\mu\text{in.}$ (0.25 μm)	Ra 5 $\mu\text{in.}$ (0.13 μm)
Polishing Process		Machine Finished	Electropolished
Assembly Environment		In specially cleaned areas	ISO Class 4 (F5 209E Class 10 equivalent) cleanroom
Packaging		Double bagged	Double bagged in cleanroom

Note: For products with higher surface finish, please contact FITOK.

Major Materials of Construction

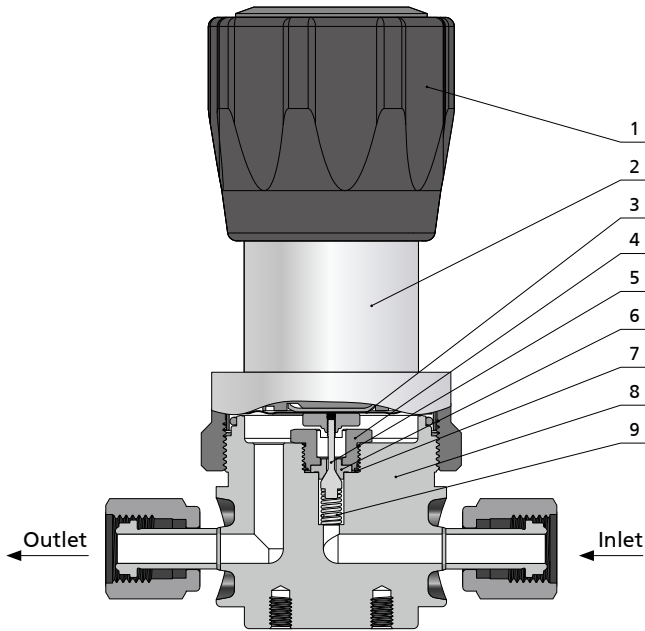

Item	Component	Material/Specification	
		6L	6LV
1	Knob Handle	ABS	
2	Bonnet	304 SS	
3	Diaphragm	Alloy 22/ASTM B575	
4	Seat Retainer	Alloy 22/ASTM B574	
5	Lift Poppet	Alloy 22/ASTM B574	
6	Seat	PCTFE/ASTM D1430 or Polyimide	
7	Gasket	316L SS	316L SS VAR
8	Body	316L SS	316L SS VAR
9	Poppet Spring	Alloy X-750	

Porting Configurations

<p>1 Inlet & 1 Outlet</p>	<p>1 Inlet & 2 Outlets</p>	<p>1 Inlet & 2 Outlets</p>
<p>1 Inlet & 3 Outlets</p>	<p>2 Inlets & 2 Outlets</p>	<p>2 Inlets & 2 Outlets</p>

Porting Configuration Symbol

IN	OUT	Gi	Go	Eout
Inlet	Outlet	Inlet Pressure Gauge Port	Outlet Pressure Gauge Port	Auxiliary Outlet

Notes:

1. IN and OUT are the inlet and outlet ports for connecting the valve to the system. Ports other than IN and OUT should not be used for system connections.
2. Porting configuration is viewed from the top.

Dimensions

Dimensions, in inches (millimeters), are for reference only.

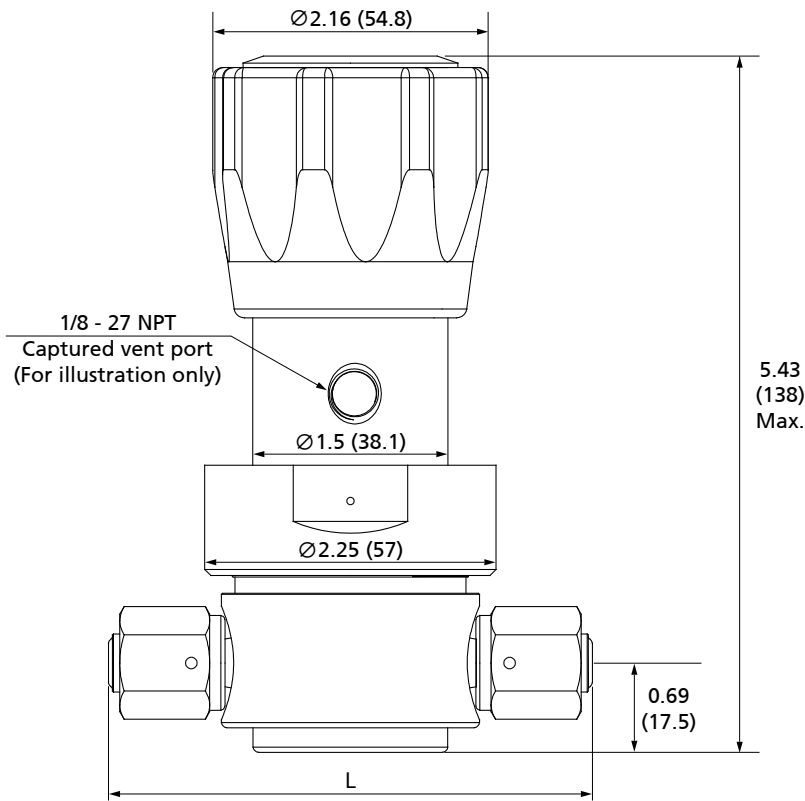

Bottom View

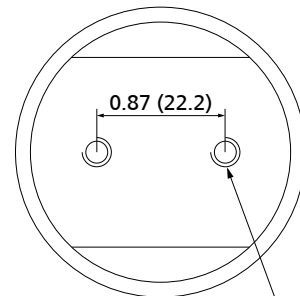

2 × M5 × 0.8-6H Thread
The holes are compatible with 10-32 mounting screws

Bottom Panel Cut-Outs

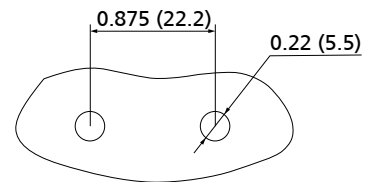

Top View

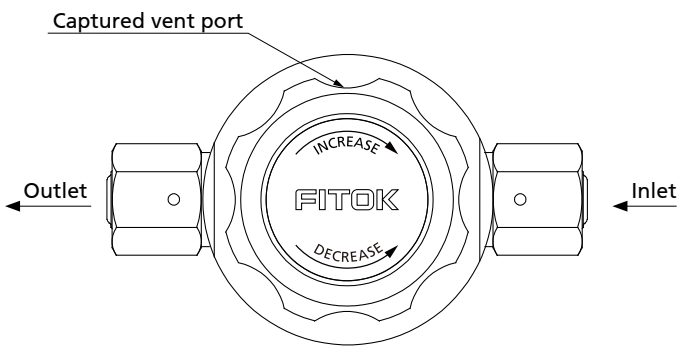

Note: Standard captured vent port position is shown as above.
For other positions, please contact FITOK or an authorized distributor.

Connection Designator	Connection Type and Size	Dimension, in.(mm)
		L
FFR4	1/4" Rotatable Female FR Fitting	3.70 (94.0)
RFR4	1/4" Rotatable Male FR Fitting	
TB4	1/4" x 0.035" Tube Butt Weld	2.96 (75.2)
TB6	3/8" x 0.035" Tube Butt Weld	
FFR8	1/2" Rotatable Female FR Fitting	4.70 (119.4)
RFR8	1/2" Rotatable Male FR Fitting	

Ordering Number Description

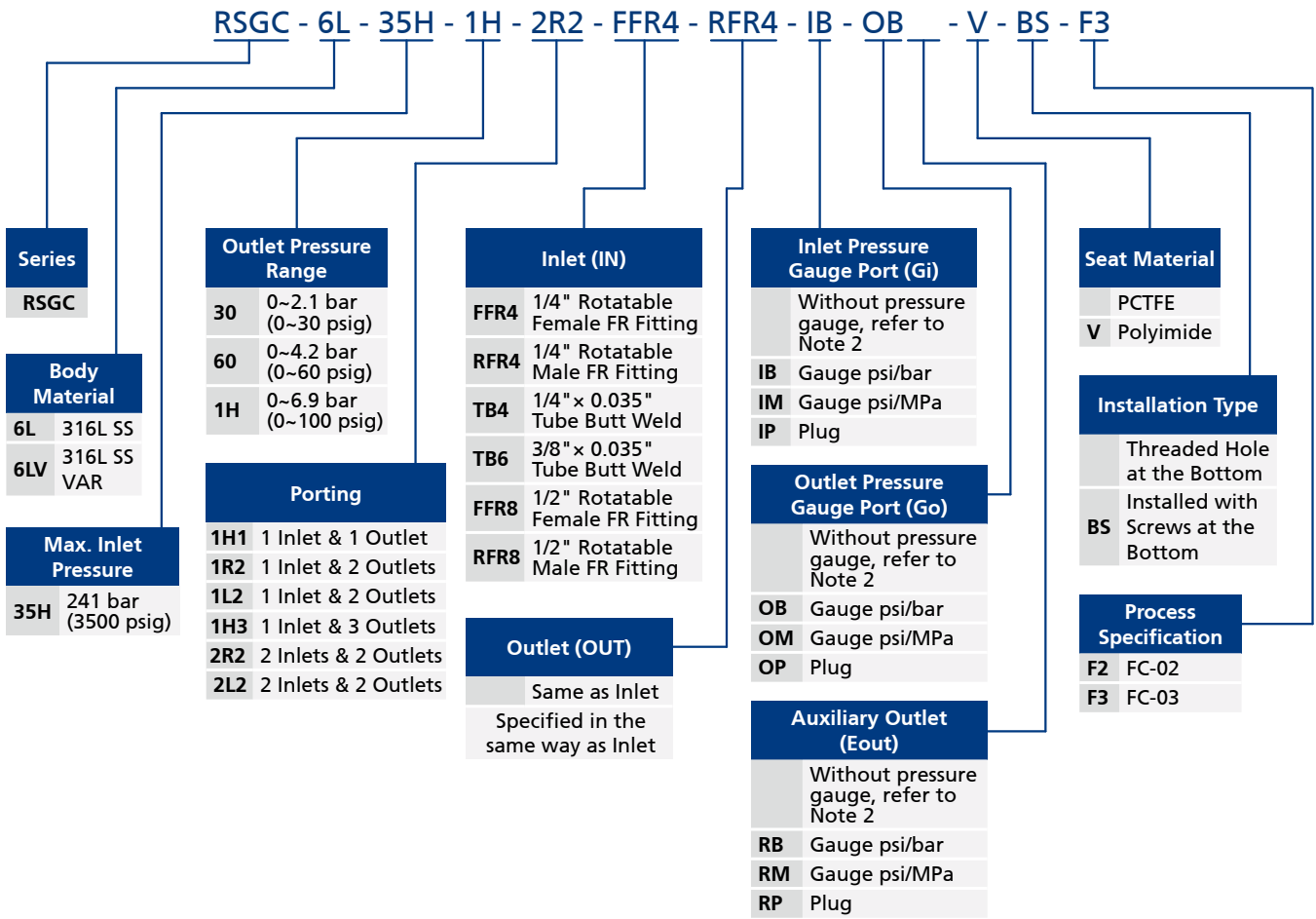

Notes:

- "Ordering Number Description" is a reference to understand the combination rules of FITOK product part number. Not all combinations are available. Should you have any questions, please contact FITOK Group or our authorized distributors.
- Without gauge: the gauge port is 1/4 in. rotatable male FR fitting.
- For the default pressure gauge configurations, please refer to the pressure gauge ordering information on [page A-12 of FITOK Full Technical Catalog For Specialty Gas Application.](#)