

Proportional Relief Valves

RV, RL and RM Series



Check Valves
Relief Valves

Proportional Relief Valves

RV, RL and RM Series

Introduction

FITOK proportional relief valves release the pressure in pipelines by diverting the flow of media as a way to protect the pipeline components. The valves open in proportion as the upstream pressure increases above the set pressure and close gradually as the upstream pressure decreases.



Features

- ⦿ Set pressure:
 - RV series: 7 color-coded springs available for a wide range of set pressures, 50 to 6000 psig @ 70°F (3.4 to 414 bar @ 20°C)
 - RL series: 10 to 225 psig @ 70°F (0.7 to 15.5 bar @ 20°C)
 - RM series: 3 color-coded springs available for a wide range of set pressures, 50 to 1500 psig @ 70°F (3.4 to 103 bar @ 20°C)
- ⦿ Maximum outlet pressure:
 - RV series: 1500 psig (103 bar)
 - RL series: 225 psig (15.5 bar)
 - RM series: 1500 psig (103 bar)
- ⦿ Orifice size:
 - RV series: 0.14" (3.6 mm)
 - RL series: 0.19" (4.8 mm) and 0.25" (6.4 mm)
 - RM series: 0.25" (6.4 mm)
- ⦿ Back pressure
 - Back pressure is the pressure of the outlet of valves. It increases the set pressure of proportional relief valves.
 - RV and RM series: Balanced stem design to eliminate the effect of system back pressure
 - RL series: Pre-set pressure = Desired pressure - 0.8 × Back pressure
- ⦿ Working temperature: -40°F to 300°F (-40°C to 148°C)
- ⦿ Variety of end connections
- ⦿ Liquid or gas service
- ⦿ Adjustable bonnet cap and adjustable set pressure
- ⦿ Lead seal lock wire through lock wire holes to lock proportional relief valve so as to secure a set pressure effectively
- ⦿ Variety of seal materials
- ⦿ Label identifies the set pressure range

Applications

Relief valves are proportional relief valves that open gradually as the pressure increases. Consequently, they do not have a capacity rating at a given pressure rise (accumulation), and they are not certified to ASME or any other codes.

- ⚠ **Some system applications require relief valves to meet specific safety codes. The system designer and user must determine when such codes apply and whether these relief valves conform to them.**
- ⚠ **FITOK proportional relief valves should never be used as ASME Boiler and Pressure Vessel Code safety relief devices.**
- ⚠ **FITOK proportional relief valves are not "Safety Accessories" as defined in the Pressure Equipment Directive 2014/68/EU.**

Pressure-Temperature Rated Value

Series	RV					RM				RL				
Max. Inlet Pressure ^①	6000 psig (414 bar), up to 8000 psig (551 bar) during relief process					6000 psig (414 bar)				300 psig (20.6 bar)				
Max. Allowable ^① Outlet Pressure	1500 psig (103 bar)					1500 psig (103 bar)				225 psig (15.5 bar)				
Set Pressure	50 to 6000 psig (3.4 to 414 bar)					50 to 1500 psig (3.4 to 105 bar)				10 to 225 psig (0.7 to 15.5 bar)				
Sealing Material	FKM	Buna-N	Neoprene	EPDM	FFKM	FKM	Buna-N	Neoprene	EPDM	FKM	Buna-N	Neoprene	EPDM	FFKM
Temperature, °C (°F)	Max. Set Pressure, psig (bar)													
-40 (-40)			-											
-34 (-30)														
-23 (-10)	-				-	-				-				-
-17 (0)														
-12 (10)		6000 (414)		6000 (414)										
-4 (25)			6000 (414)					1500 (103)						
-1 (30)							1500 (103)		1500 (103)					
4 (40)	6000 (414)				6000 (414)									
10 (50)														
20 (70)										225 (15.5)				
65 (150)	5580 (384)	5580 (384)	3000 (207)	5580 (384)	5580 (384)									225 (15.5)
93 (200)	5160 (355)	5160 (355)	1500 (103)	5160 (355)	5160 (355)			700 (48)						
121 (250)	4910 (338)	4910 (338)		4910 (338)	4910 (338)									
135 (275)			-		2500 (172)									
148 (300)	-	-												

① Outlet pressure shall not exceed inlet pressure.

Set Pressure and Resealing Pressure

Set pressure: the upstream pressure at which the valve opens and the indication of flow occurs.

Set pressure of each valve after initial relief fluctuates within:

±3.0 psig (0.20 bar) or ±5% (whichever is greater) of the initial set pressure at 60 to 80°F (15 to 26°C),

±6.0 psig (0.40 bar) or ±20% (whichever is greater) of the initial set pressure below 60°F (15°C) or above 80°F (26°C).

Note: For valves not opened for a period of time, the set pressure may be higher.

Resealing pressure: the upstream pressure at which the valve is fully closed as a result of a drop of upstream pressure after the valve opens. Resealing pressure is always lower than set pressure.

The valve is tested for set and resealing performance before shipment.

Series	Test Set Pressure psig (bar)	Minimum Resealing Pressure as a Percentage of Set Pressure, %
RL	10 to 20 (0.7 to 1.3)	50
	175 to 225 (12.0 to 15.5)	91
RV/RM	100 to 200 (6.8 to 13.7)	50
	850 to 1000 (58.5 to 68.9)	85

Flow Data at 70°F (20°C)

Air

RV and RM Series

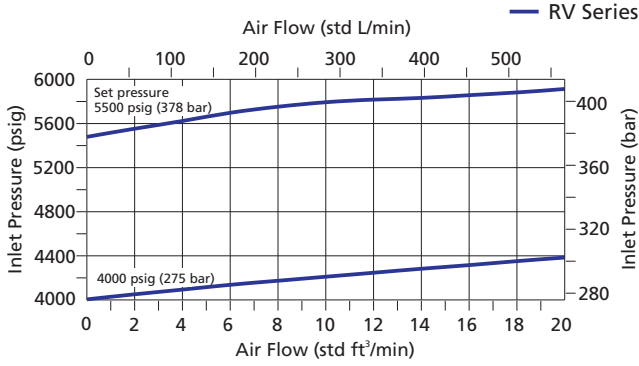

Water

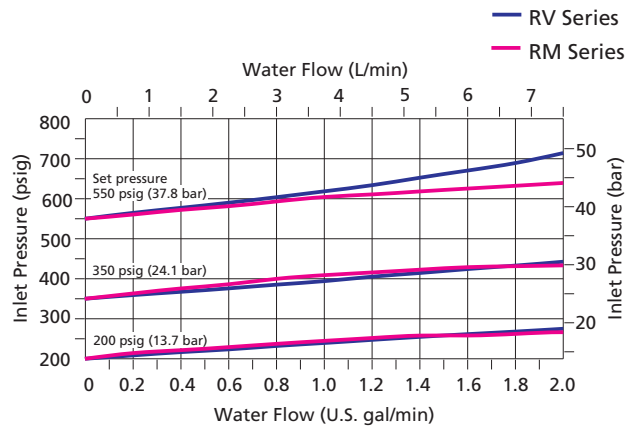
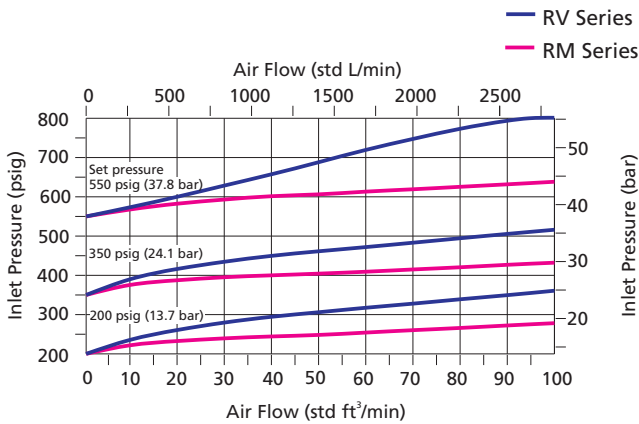
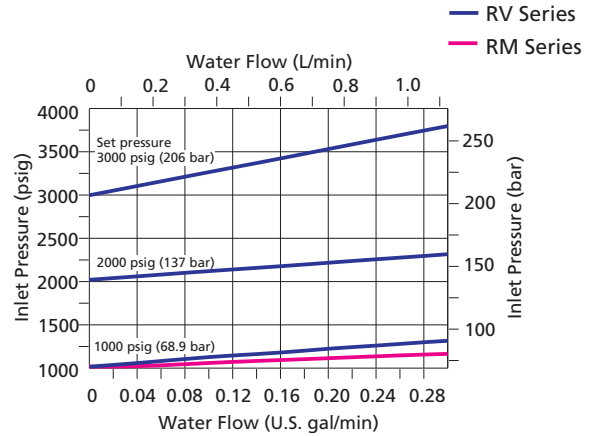
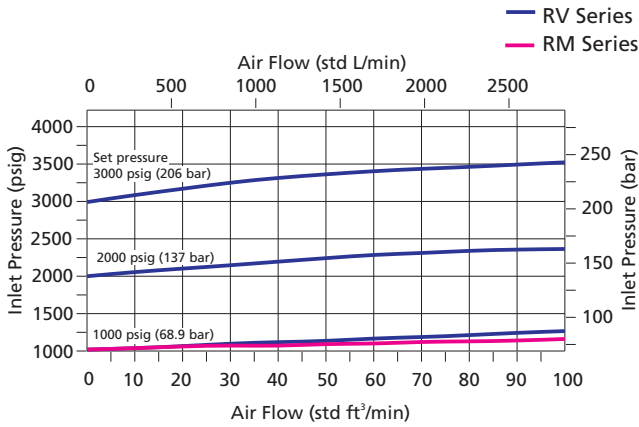
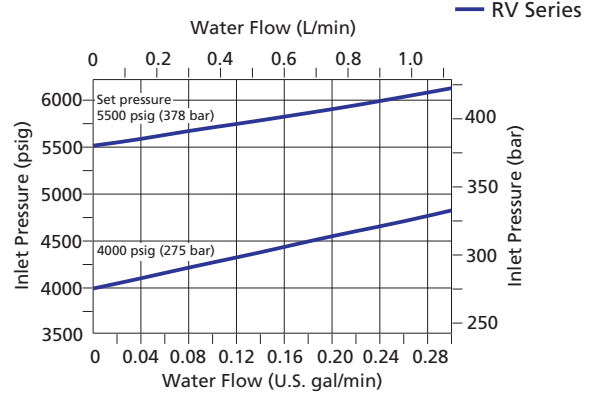

RL Series

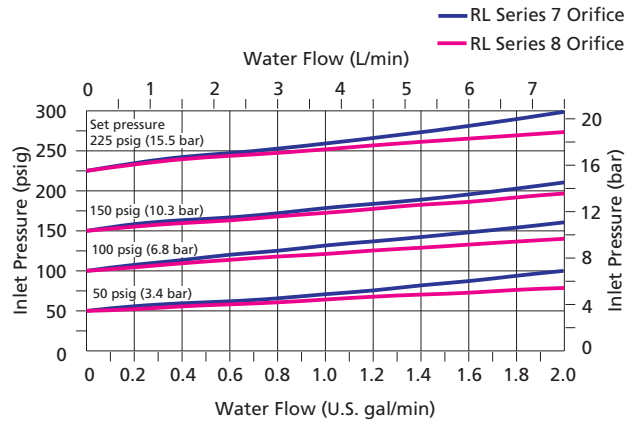
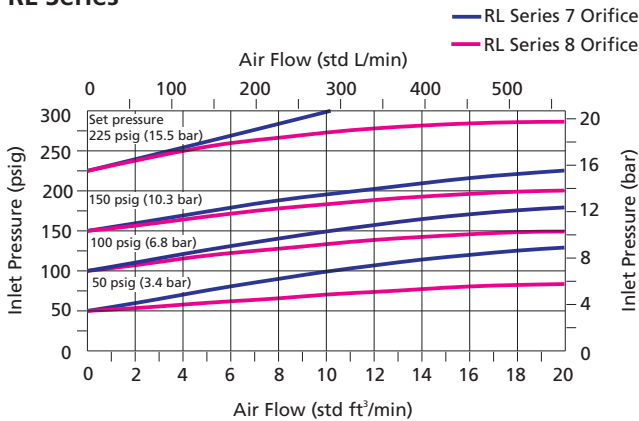

Check Valves
Relief Valves

Standard Materials of Construction

RV Series

Component		Material Grade/ASTM Specification
1	<i>Body</i>	316 SS/A182
2	<i>Seat</i>	316 SS/A479
3	<i>O-ring</i>	Fluorocarbon FKM
4	<i>Gasket</i>	PEEK
5	<i>Seat Retainer</i>	316 SS/A479
6	<i>O-ring</i>	Fluorocarbon FKM
7	<i>Stem</i>	316 SS/A479
8	<i>O-ring</i>	Fluorocarbon FKM
9	<i>Bonnet</i>	316 SS/A479
10	Spring Support	316 SS/A479
11	Spring	S17700 SS/AMS 5678
12	Lock Nut	17-4PH powdered metal
13	Label	Polyester
14	Bonnet Cap	316 SS/A479

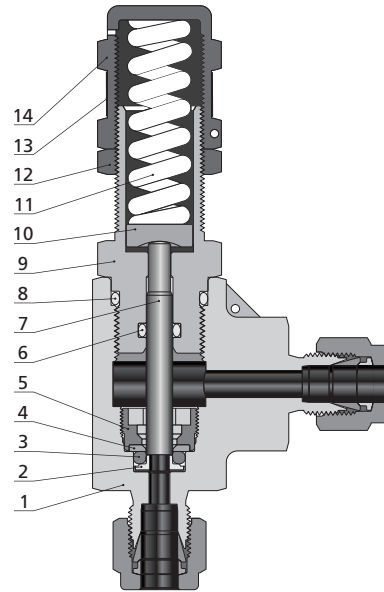

Note: Wetted components are listed in italics.

1. Lubricant: Silicone-based
2. Contact FITOK Group or our authorized distributors for other materials

RL Series

Component		Material Grade/ASTM Specification
1	<i>Body</i>	316 SS/A182
2	<i>Gasket</i>	316 SS/A479
3	<i>Seat</i>	316 SS/A479
4	<i>Bonded disc</i>	316 SS/A479+Fluorocarbon FKM
5	<i>Stem</i>	316 SS/A479
6	<i>Retainer</i>	316 SS/A479
6a	<i>Ring</i>	316 SS/A479
7	<i>Quad Seal</i>	Fluorocarbon FKM
8	<i>O-ring</i>	Fluorocarbon FKM
9	<i>Bonnet</i>	316 SS/A479
10	Spring Support	316 SS/A479
11	Spring	S17700 SS/AMS 5678
12	Lock Nut	17-4PH powdered metal
13	Sleeve	304SS/A240
14	Label	Polyester
15	Bonnet Cap	316 SS/A479

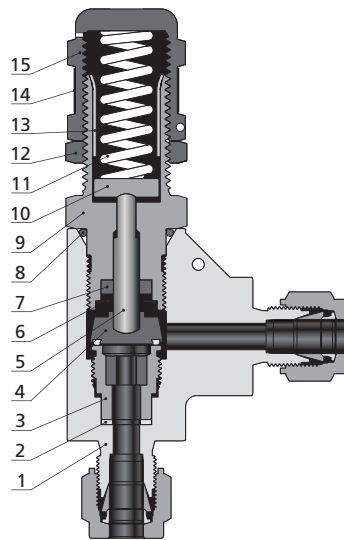

Orifice 7
0.19 in. (4.8 mm)

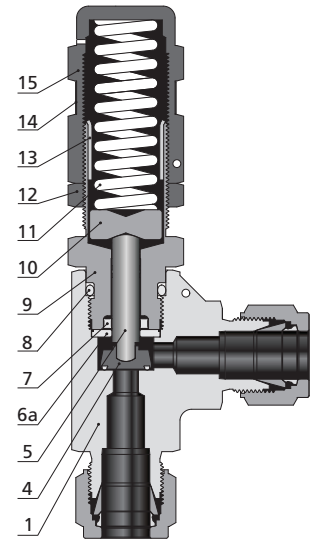

Orifice 8
0.25 in. (6.4 mm)

Note: Wetted components are listed in italics.

1. Lubricant: Silicone-based
2. Contact FITOK Group or our authorized distributors for other materials

RM Series

Component		Material Grade/ASTM Specification
1	<i>Body</i>	316 SS/A182
2	<i>Stem</i>	316 SS/A479+Fluorocarbon FKM
3	<i>Retainer</i>	316 SS/A479
4	<i>Square sealing piece</i>	Fluorocarbon FKM
5	<i>Bonnet</i>	316 SS/A479
6	<i>O-ring</i>	Fluorocarbon FKM
7	Spring Support	316 SS/A479
8	Spring	S17700 SS/AMS 5678
9	Lock Nut	17-4PH powdered metal
10	Label	Polyester
11	Bonnet Cap	316 SS/A479

Note: Wetted components are listed in italics.

1. Lubricant: Silicone-based
2. Contact FITOK Group or our authorized distributors for other materials

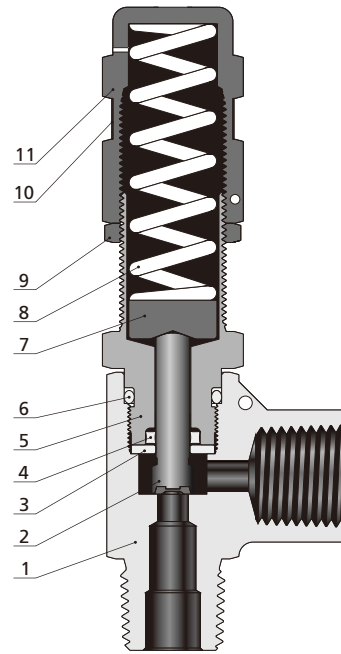

Manual Override Handles

Lift the aluminum handle with hand to open the proportional relief valve without changing the set pressure. For use on the following valves :

- RV Series — set pressure range 50~1500 psig(3.4~103.4 bar)
- RL Series — set pressure range 10~225 psig(0.7~15.5 bar)
- RM Series— set pressure range 50~300 psig(3.4~20.7 bar)

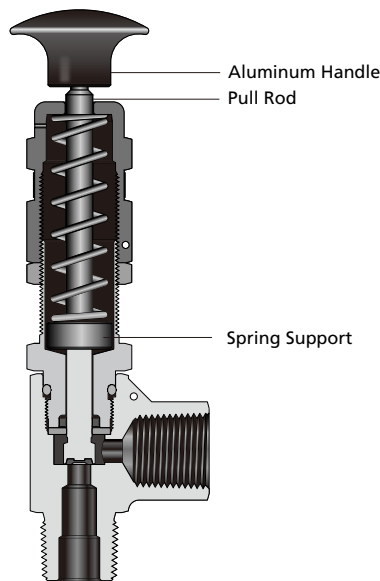

Check Valves
Relief Valves

Dimensions

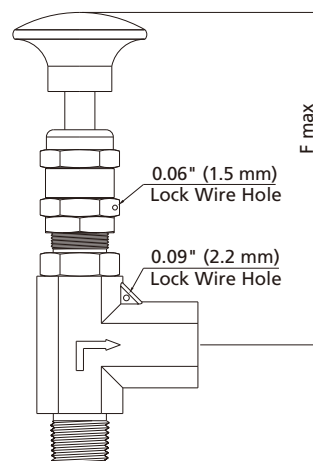
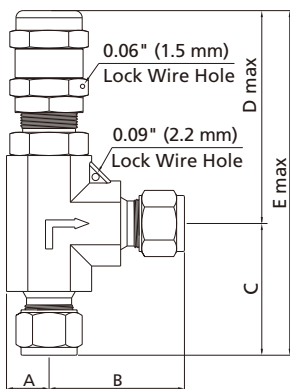

RV Series

Basic Ordering Number	Connection Type and Size		Orifice in. (mm)	Dimensions, in. (mm)					
	Inlet	Outlet		A	B	C	D	E	F
RV□□-FL4-6-□	1/4" FITOK	1/4" FITOK	0.14 (3.6)	0.46 (11.9)	1.60 (40.6)	1.44 (36.6)	2.70 (68.6)	4.14 (105.2)	3.68 (98.0)
RV□□-FL6-6-□	3/8" FITOK	3/8" FITOK							
RV□□-FL8-6-□	1/2" FITOK	1/2" FITOK							
RV□□-ML6-6-□	6 mm FITOK	6 mm FITOK		0.46 (11.9)	1.60 (40.6)	1.44 (36.6)	2.70 (68.6)	4.14 (105.2)	
RV□□-ML8-6-□	8 mm FITOK	8 mm FITOK							
RV□□-ML12-6-□	12 mm FITOK	12 mm FITOK							
RV□□-FNS4-6-□	1/4 Female NPT	1/4 Female NPT		0.46 (11.9)	1.17 (29.7)	1.38 (34.9)	2.70 (68.6)	4.08 (103.5)	
RV□□-NS4-6-□	1/4 Male NPT	1/4 Male NPT							
RV□□-FRT4-6-□	1/4 Female BSPT	1/4 Female BSPT							

RL Series

Basic Ordering Number	Connection Type and Size		Orifice in. (mm)	Dimensions, in. (mm)					
	Inlet Size	Outlet Size		A	B	C	D	E	F
RL□□-FL4-7	1/4" FITOK	1/4" FITOK	0.19 (4.8)	0.46 (11.9)	1.60 (40.6)	1.44 (36.6)	2.70 (68.8)	4.14 (105.0)	3.74 (95.0)
RL□□-ML6-7	6 mm FITOK	6 mm FITOK							
RL□□-NS4-7	1/4 Male NPT	1/4 Male NPT							
RL□□-RT4-7	1/4 Male BSPT	1/4 Male BSPT			1.17 (29.7)	1.38 (34.9)	4.08 (103.5)		
RL□□-FNS4-7	1/4 Female NPT	1/4 Female NPT							
RL□□-FRT4-7	1/4 Female BSPT	1/4 Female BSPT							
RL□□-FL8-8	1/2" FITOK	1/2" FITOK	0.25 (6.4)	0.54 (13.7)	1.83 (46.5)	1.83 (46.5)	3.87 (98.4)	5.92 (150.0)	4.89 (124.3)
RL□□-ML12-8	12 mm FITOK	12 mm FITOK							
RL□□-NS8-8	1/2 Male NPT	1/2 Male NPT							
RL□□-RT8-8	1/2 Male BSPT	1/2 Male BSPT							
RL□□-FNS8-8	1/2 Female NPT	1/2 Female NPT							
RL□□-FRT8-8	1/2 Female BSPT	1/2 Female BSPT			0.58 (14.7)				

Check Valves
Relief Valves

RM Series

Basic Ordering Number	Connection Type and Size		Orifice in. (mm)	Dimensions, in. (mm)					
	Inlet Size	Outlet Size		A	B	C	D	E	F
RM□□-FL8-8-□	1/2" FITOK	1/2" FITOK	0.25 (6.4)	0.54 (13.7)	1.83 (46.5)	1.83 (46.5)	3.87 (98.4)	5.73 (145.0)	4.89 (124.3)
RM□□-ML12-8-□	12 mm FITOK	12 mm FITOK							
RM□□-NS8-8-□	1/2 Male NPT	1/2 Male NPT							
RM□□-RT8-8-□	1/2 Male BSPT	1/2 Male BSPT		0.58 (14.7)	1.44 (36.6)	1.44 (36.6)	5.31 (135.0)		
RM□□-FNS8-8-□	1/2 Female NPT	1/2 Female NPT							
RM□□-FRT8-8-□	1/2 Female BSPT	1/2 Female BSPT							

1. FITOK means FITOK double ferrule tube fittings.
2. Dimensions are shown with FITOK nuts finger-tightened. All dimensions are for reference only and are subject to change.
3. Sizes and types listed are standard. For other connection types and sizes, please contact FITOK Group or our authorized distributors.

Sealing Kit

Series	Orifice Designator	Sealing Kit Basic Ordering Number					Sealing Kit Content
		FKM	Buna-N	Neoprene	EPDM	FFKM	
RV	6	VI-RV-6	BN-RV-6	N-RV-6	E-RV-6	Z-RV-6	O-ring (3)
RL	7	RLSS-7-VI	RLSS-7-B	RLSS-7-N	RLSS-7-E	RLSS-7-Z	O-ring, square sealing piece, adhesive disc, retainer
	8	RLSS-8-VI	RLSS-8-B	RLSS-8-N	RLSS-8-E	RLSS-8-Z	O-ring, square sealing piece, adhesive disc
RM	8	RMSS-8-VI	RMSS-8-B	RMSS-8-N	RMSS-8-E	-	O-ring, square sealing piece, stem

The basic ordering number of the listed RL and RM series sealing kits specifies 316 stainless steel.
For other materials, such as alloy 400, replace SS with M in the basic ordering number, for example: RLM-7-VI

Spring Kit

Series	Orifice Designator	Spring Kit Basic Ordering Number	Set Pressure Range psig (bar)	Spring Color
RV	6	7PRV-SP6-F-B	50 to 300 (3.4 to 20.7)	Green
		7PRV-SP6-O-B	300 to 700 (20.7 to 48.3)	Orange
		7PRV-SP6-Y-B	700 to 1500 (48.3 to 103)	Yellow
		7PRV-SP6-P-B	1500 to 2500 (103 to 172)	Purple
		7PRV-SP6-W-B	2500 to 3500 (172 to 241)	White
		7PRV-SP6-J-B	3500 to 4500 (241 to 310)	Blue
		7PRV-SP6-C-B	4500 to 6000 (310 to 414)	Red
RL	7	7PRL-SP7-Y-B	10 to 225 (0.7 to 15.5)	Yellow
	8	7PRL-SP8-Y-B		
RM	8	7PRM-SP8-F-B	50 to 300 (3.4 to 20.7)	Green
		7PRM-SP8-O-B	300 to 700 (20.7 to 48.3)	Orange
		7PRM-SP8-Y-B	700 to 1500 (48.3 to 103)	Yellow

The content of the spring kit includes: spring and label.
To order spring kit with springs, labels, and lead seal lock wire, add "-L" to the spring kit basic ordering number.
For example: 7PRV-SP6-F-B-L.

Ordering Number Description

Valves

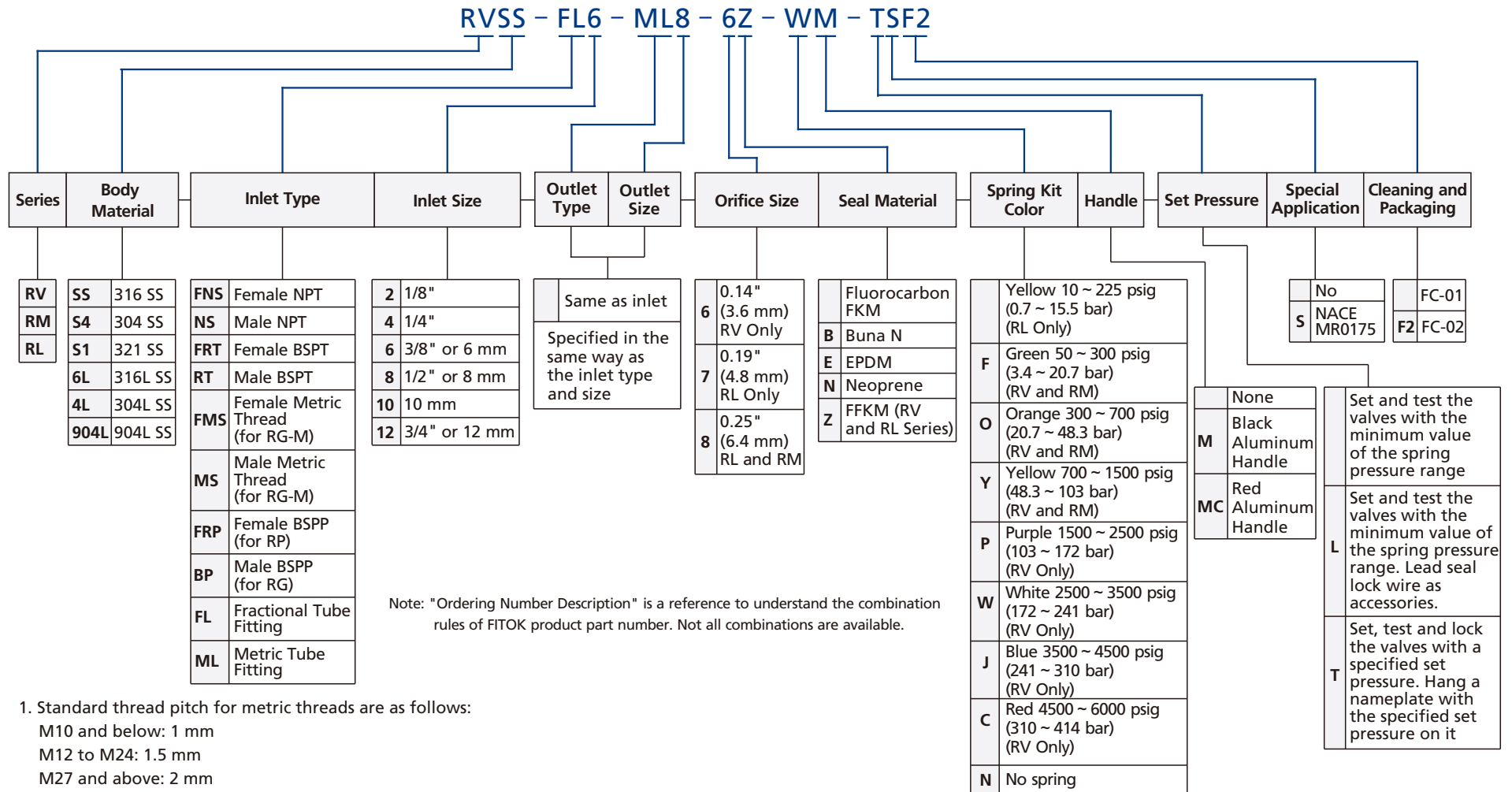

1. Standard thread pitch for metric threads are as follows:

- M10 and below: 1 mm
- M12 to M24: 1.5 mm
- M27 and above: 2 mm

Standard thread pitch should be ignored in the ordering number, others should be specified.

2. Cleaning and Packaging:

- FC-01: Standard cleaning and packaging for general industrial procedures.
- FC-02: Special cleaning and packaging for wetted system components to ensure compliance with product cleaning requirement of ASTM G93 Level C.

3. For proportional relief valve with a specified set pressure and a nameplate, specify the desired set pressure when ordering.

The set pressure value should be within the set pressure range of the selected spring, and the following requirements should be followed:

- 10 psig ≤ set pressure value ≤ 500 psig, take the minimum interval 1 psig.
- 500 psig ≤ set pressure value ≤ 1000 psig, take the minimum interval of 5 psig.
- 1000 psig ≤ set pressure value ≤ 6000 psig, take the minimum interval of 10 psig.

info@fitok.com
www.fitok.com

FK-IC-GV-07-EN-250122